

5

5. Adjust the 4 legs, and tighten all the screws.

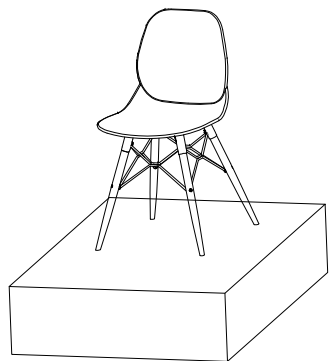

6

6. Put the protect cap on the nut.

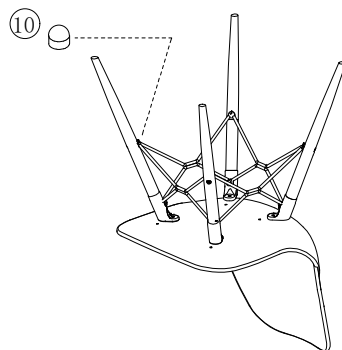

Each product contains

Number	Picture	Quantity	Number	Picture	Quantity	Additional accessories
①		1	⑥		4	1
②		4	⑦		4	1
③		1	⑧		4	1
④		2	⑨		4	1
⑤		2	⑩		4	1
					X 1	
					X 1	

PW-025NP



Assembly instructions

1

1. The plastic parts with E installed on the front, plastic parts G on the back, fixed them with screw (keep loose).

! The position of plastic parts E and G can not be confounded.

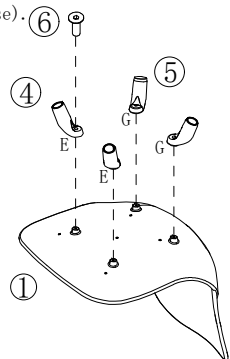

2

2. As shown in the picture, put 4 legs in the plastic parts accordingly.

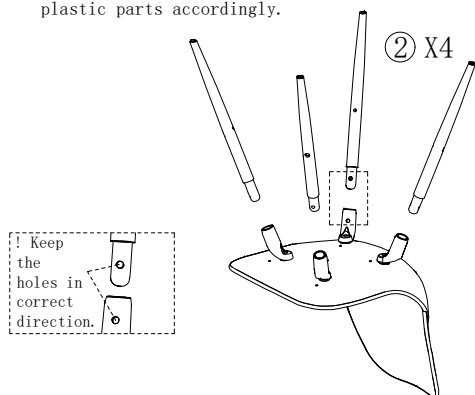

3

3. Put the steel frame in the position, as shown in the picture.

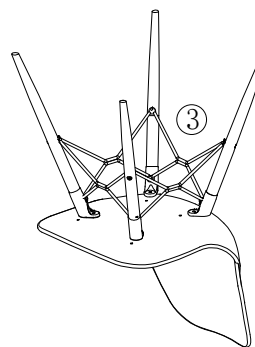

4

4. Tighten the screws with nuts.

