

# Parade

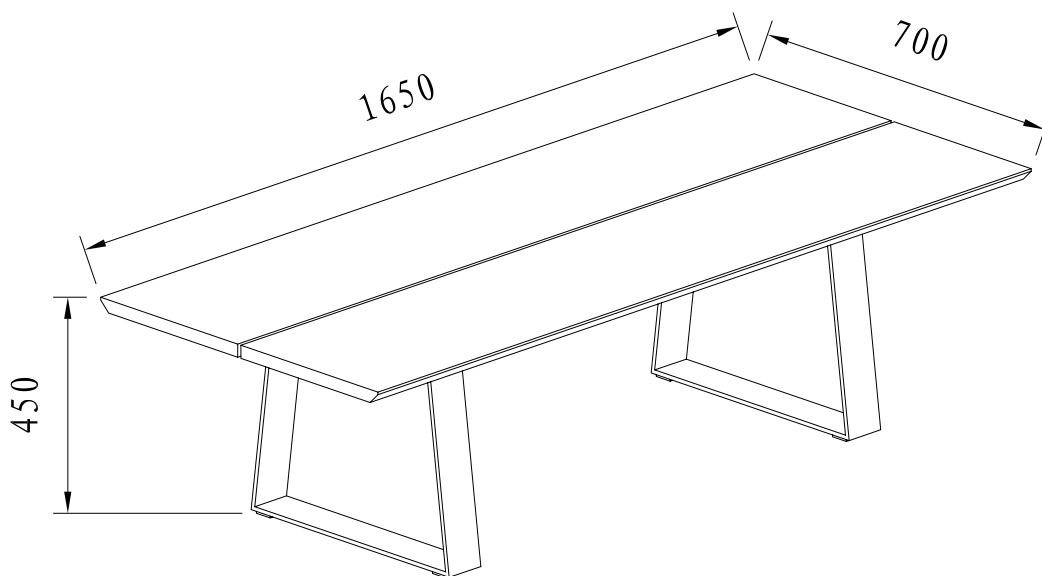

**N:** Viktig; Les nøye og oppbevar for bruk senere.

**D:** Wichtig! Sorgfältig lesen und für spätere Verwendung aufbewahren.

**UK:** Important! Read carefully and retain for future reference.

**F:** Important! A lire soigneusement et à conserver.

**SE:** Viktigt : Läs noggrant och spara för senare behov.

**ES:** Importante. Leer cuidadosamente las instrucciones y guardar para futuras referencias.

**I:** Importante! Leggere attentamente e conservare per future necessità.

**N:** For å unngå at møbelet får skader under montering anbefales det å montere møbelet på et mykt underlag, f.eks. på et teppe.

**UK:** Assembling of the furniture should take place on a soft surface e.g. a carpet in order to avoid scratching during assembly.

**D:** Um zu vermeiden, dass das Möbelstück gerissen wird, empfehlen wir unbedingt, es auf einer weichen Unterlage zu montieren - z.B. ein Teppich.

**F:** Afin d'éviter les rayures lors du montage, l'assemblage du meuble doit être effectué sur une surface douce - par exemple une couverture.

**SE:** För att möbeln inte ska repas vid montering bör den monteras på ett mjukt underlag - tex. på en matta.

**ES:** El montaje del sofa tiene que ser hecho en una superficie suave, como por ejemplo una alfombra o una manta, para evitar rozaduras durante el montaje.

**I:** Il montaggio dei mobili dovrebbe essere eseguito su una superficie morbida, ad esempio su un tappeto, per evitare rigature dovute all'assemblaggio.

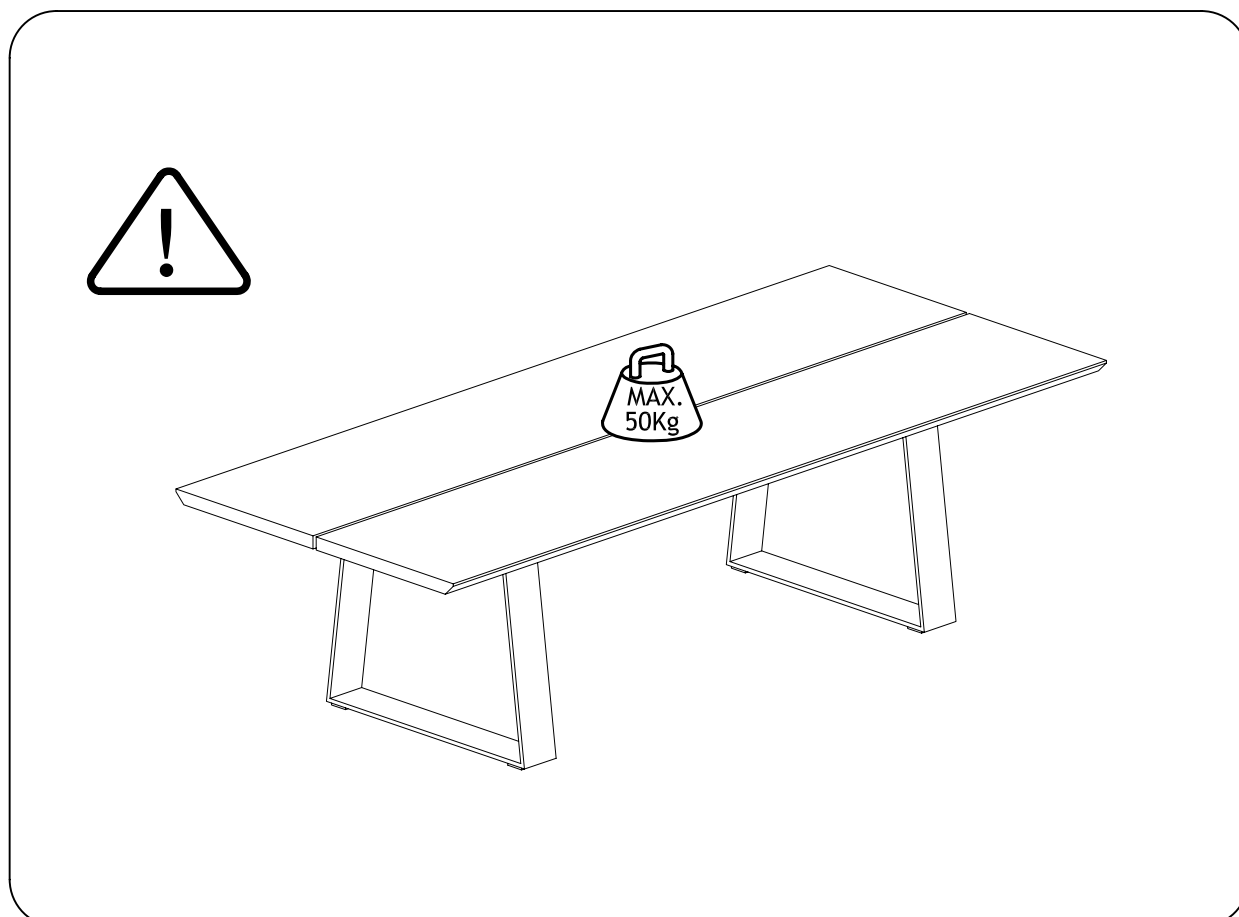
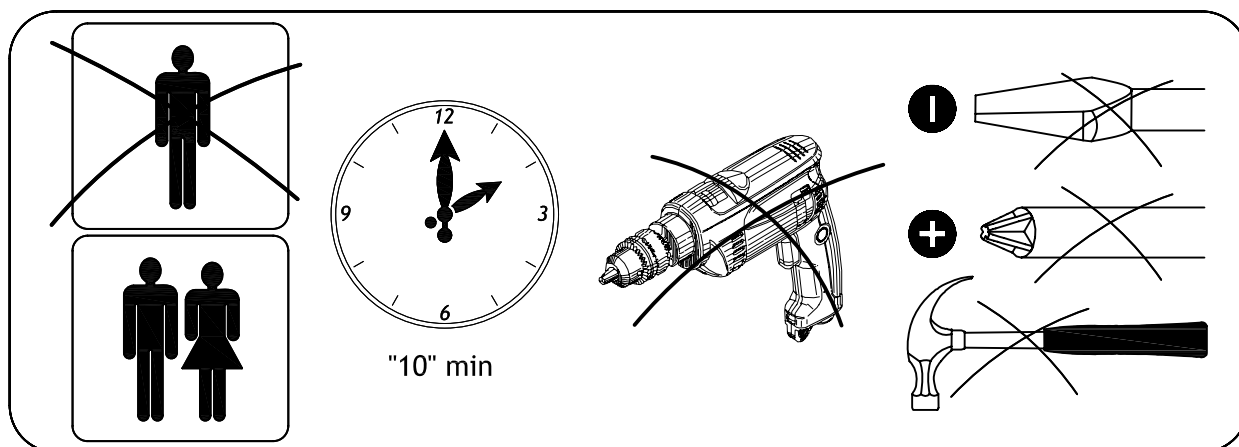
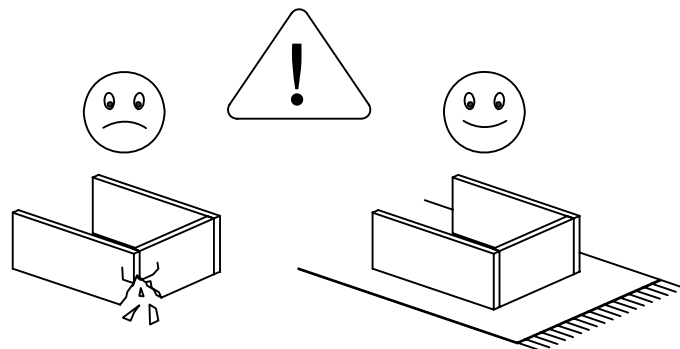

Part	Qty	Dimension	Kolli
1	2	1650*346*26	1/2
2	1	1090*400*40	1/2
3	2	500*80*385	2/2

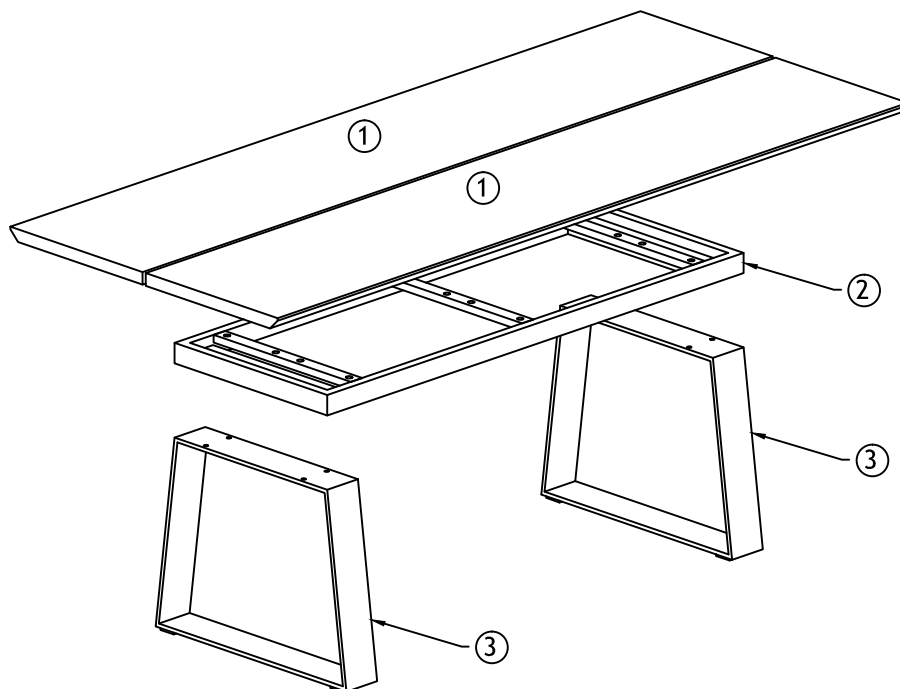

ID nr.5212



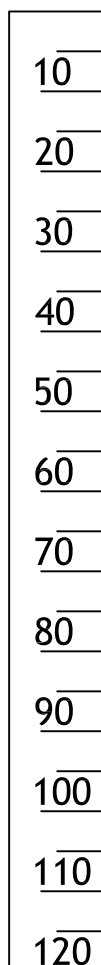

mm

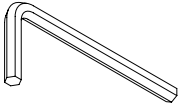
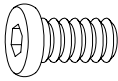

<p>A x 1</p>  <p>5MM</p>	<p>B x 20</p>  <p>M8x30</p>	<p>C x 20</p>  <p>Ø17xØ8x1.5</p>	<p>D x 4</p>  <p>76*56*2</p>
-----------------------------------------------------------------------------------------------------------	--------------------------------------------------------------------------------------------------------------	--------------------------------------------------------------------------------------------------------------------	-----------------------------------------------------------------------------------------------------------------

**N:** Dersom det skulle være nødvendig å bestille reservedeler, vennligst oppgi både modell- og delenummer.

**D:** Falls Sie Ersatzteile benötigen, geben Sie bitte Modellnummer und Teilnummer, die Sie in der Montageanleitung findet an.

**UK:** In case you need spare parts please indicate model number and part number shown in the assembly instruction.



**F:** Dans le cas où vous auriez besoin de pièces détachées, nous vous prions de bien vouloir indiquer la référence du produit et celle de la pièce en question.

**SE:** Om det blir nödvändigt att beställa reservdelar, var vänlig uppge både modellnummer och det angivna numret på reservdelen.

**ES:** En caso de que usted necesite alguna pieza de cambio, por favor, indicar modelo y número conforme aparece en las instrucciones.

**I:** Nel caso in cui siano necessarie delle parti di ricambio, indicare il numero del modello e il numero della parte indicati nelle istruzioni di montaggio.



# 1

A x 1	B x 12	C x 12
		
5MM	M8x30	Ø17xØ8x1.5

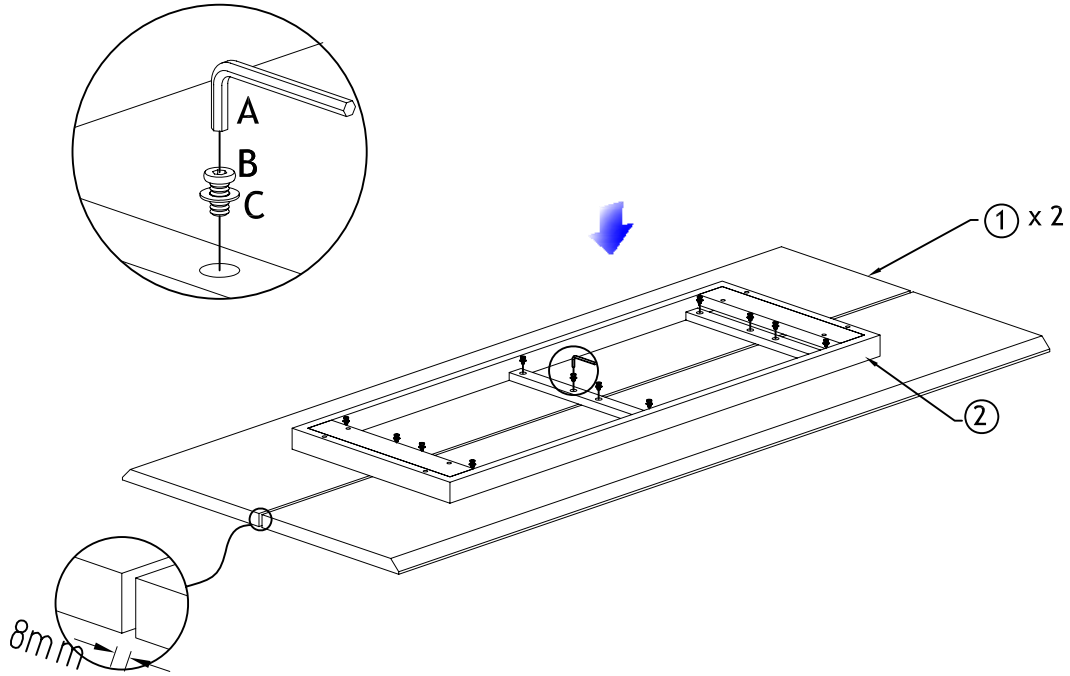
Viktig! For at bordet skal bli stabilt er det viktig at disse boltene skrues hardt til.



# 2

A x 1	B x 8	C x 8
		
5MM	M8x30	Ø17xØ8x1.5

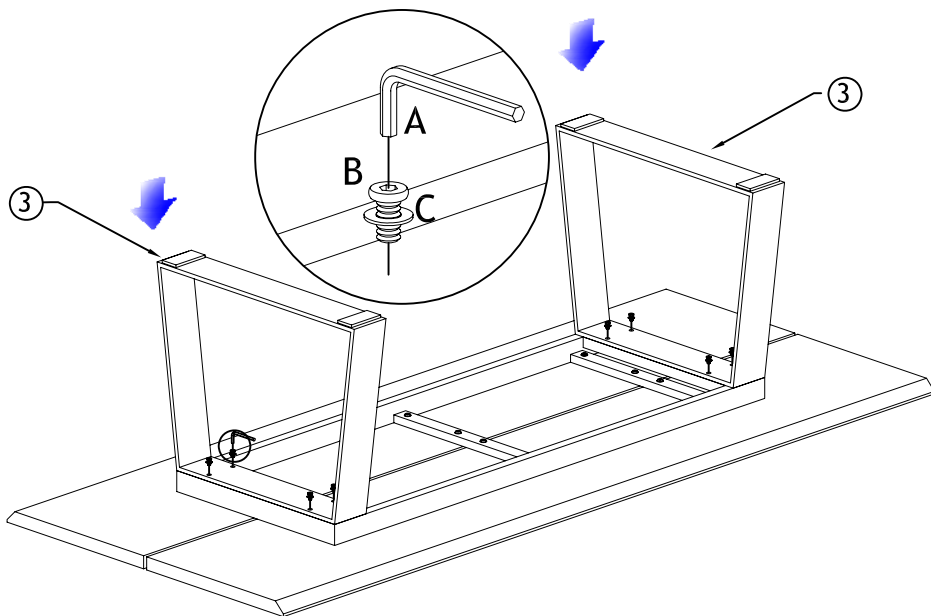

3

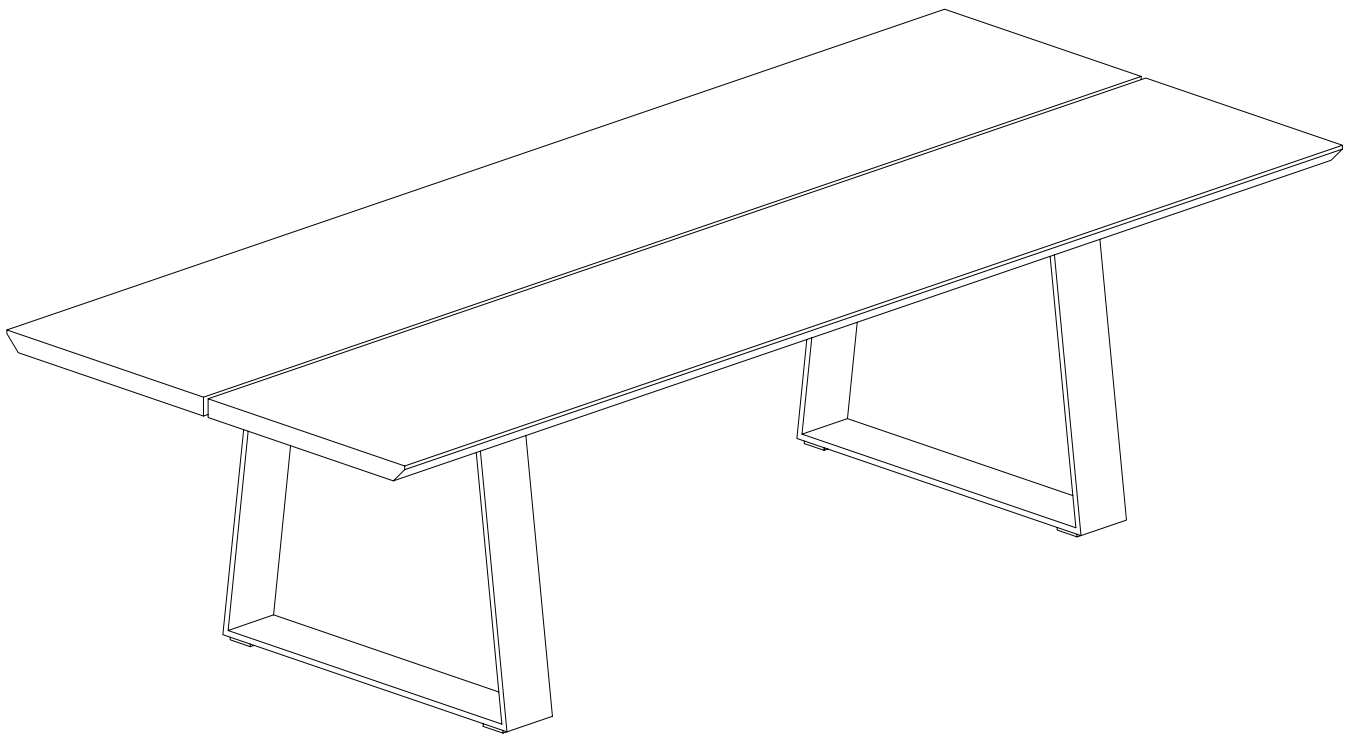

NO:

**Vedlikeholdsveiledning:**

Kontroller og etterstram alle skruer regelmessig. Tørk av ukentlig med en ren og tørr klut. NB! Ikke bruk såpemidler, ei heller slipemidler, kjemikalier eller pussemidler som inneholder silikon. Unngå at skapet blir eksponert for direkte sollys da det kan medføre at treet endrer farge. Fuktige flekker må fjernes omgående. Det er viktig at bordet etterbehandles jevnlig med Opalin eller Leather Master Wax Spray for å gjøre overflatene mer motstandsdyktige mot smuss og væske. Følganvisningen på produktet nøy.

UK:

**Care information:**

Periodically check and re-tighten all fasteners. Dust weekly using a soft, clean cloth. Do not use harsh abrasives, chemicals or polishes containing silicone. Avoid direct sunlight as this may cause the timber to change color. Moist substances must be removed immediately. It is important that the table is treated with Opalin or Leather Master Wax Spray regularly to make surfaces more resistant towards fluids and stains. Follow instructions on the product carefully.