

Grace

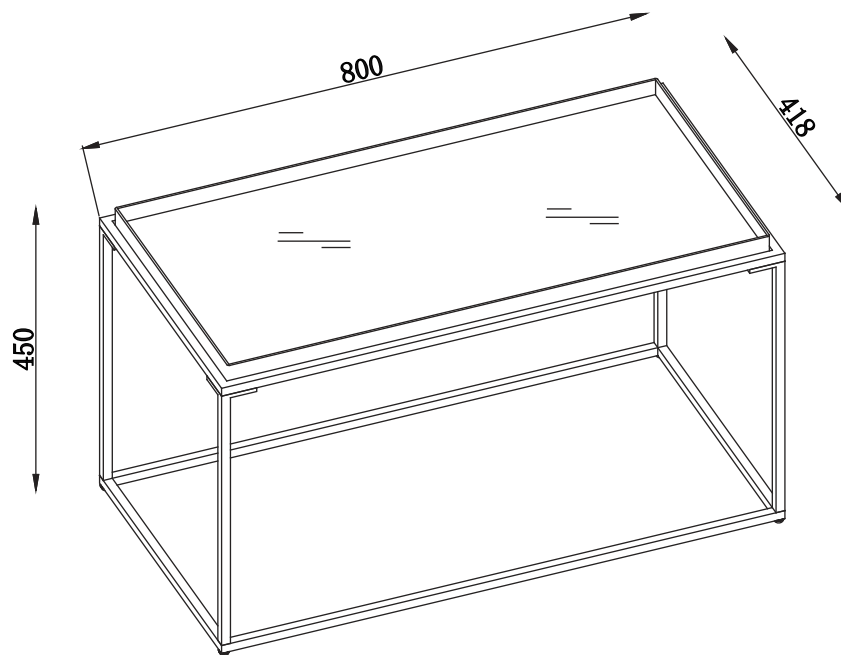

N: Viktig; Les nøye og oppbevar for bruk senere.

D: Wichtig! Sorgfältig lesen und für spätere Verwendung aufbewahren.

UK: Important! Read carefully and retain for future reference.

F: Important! A lire soigneusement et à conserver.

SE: Viktigt : Läs noggrant och spara för senare behov.

ES: Importante. Leer cuidadosamente las instrucciones y guardar para futuras referencias.

I: Importante! Leggere attentamente e conservare per future necessità.

N: For å unngå at møbelet får skader under montering anbefales det å montere møbelet på et mykt underlag, f.eks. på et teppe.

UK: Assembling of the furniture should take place on a soft surface e.g. a carpet in order to avoid scratching during assembly.

D: Um zu vermeiden, dass das Möbelstück gerissen wird, empfehlen wir unbedingt, es auf einer weichen Unterlage zu montieren - z.B. ein Teppich.

F: Afin d'éviter les rayures lors du montage, l'assemblage du meuble doit être effectué sur une surface douce - par exemple une couverture.

SE: För att möbelen inte ska repas vid montering bör den monteras på ett mjukt underlag - tex. på en matta.

ES: El montaje del sofa tiene que ser hecho en una superficie suave, como por ejemplo una alfombra o una manta, para evitar rozaduras durante el montaje.

I: Il montaggio dei mobili dovrebbe essere eseguito su una superficie morbida, ad esempio su un tappeto, per evitare rigature dovute all'assemblaggio.

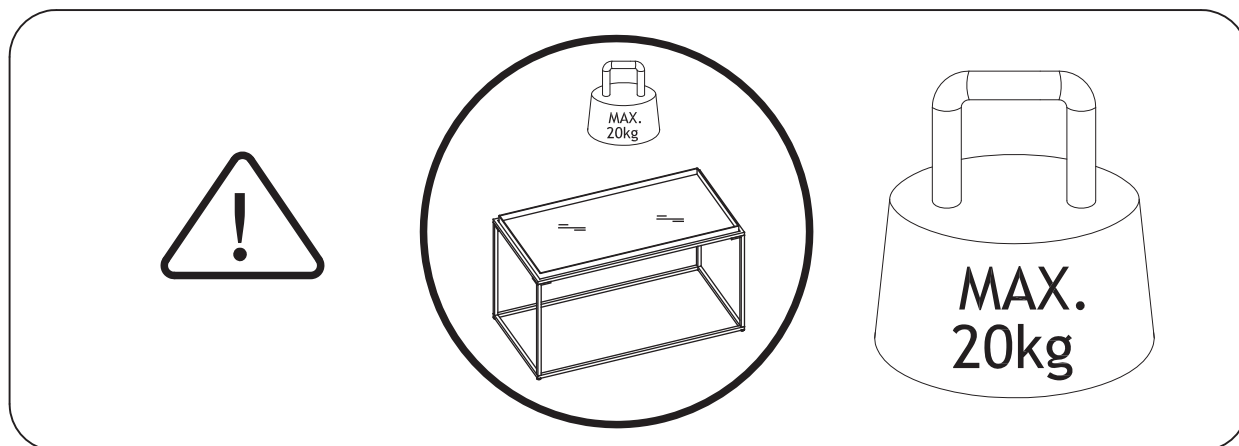
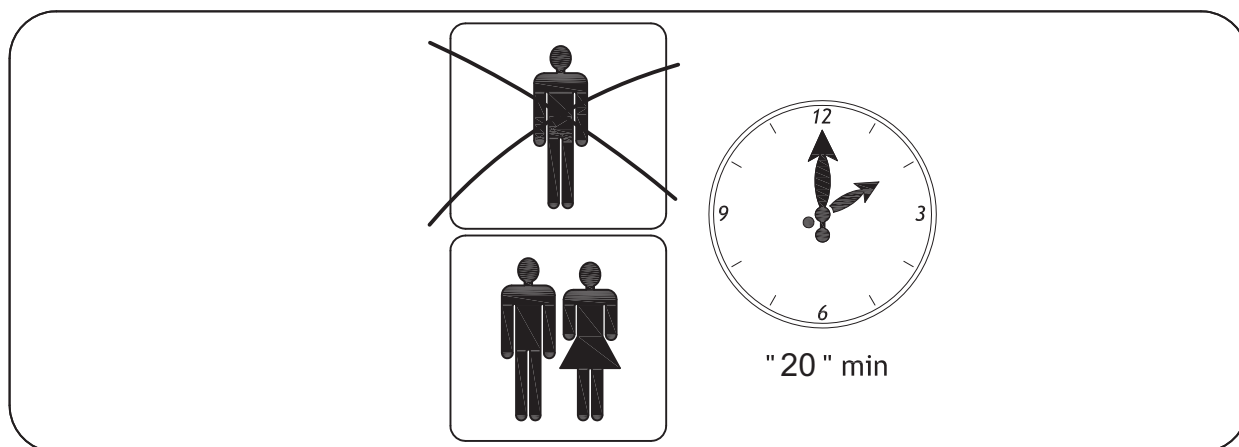
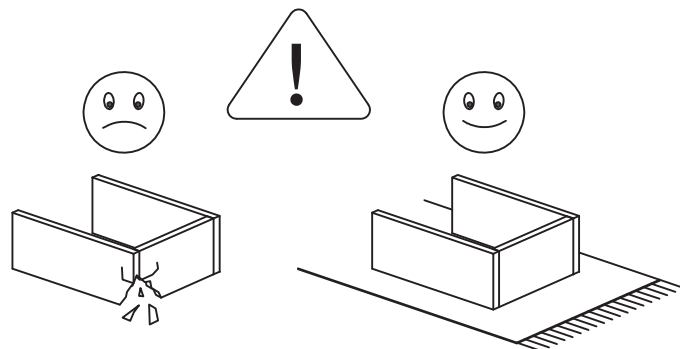

			✓
1	1	800x418x13	
2	4	50x50x400	
3	1	800x418x13	
4	1	770x390x30	
5	1	763x383x5	

ID NO.: 5318

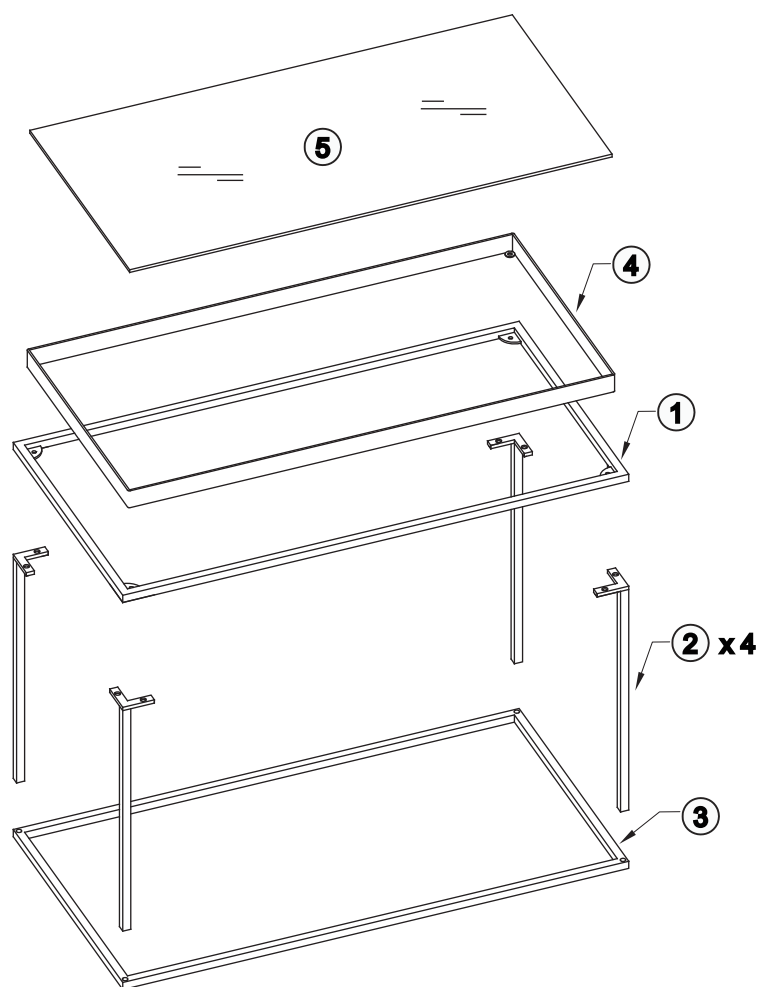



ID NO.: 5318

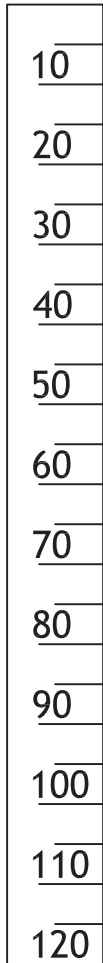

mm

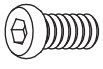
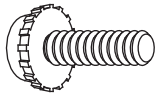

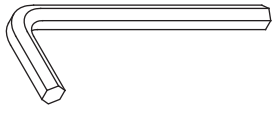
A x 8	B x 4	C x 4	D x 1
			
M6 x 12 mm	Φ15 x 26 mm	Φ12 x 4 mm	4 mm

N: Dersom det skulle være nødvendig å bestille reservedeler, vennligst oppgi både modell- og delenummer.

D: Falls Sie Ersatzteile benötigen, geben Sie bitte Modellnummer und Teilnummer, die Sie in der Montageanleitung finden an.

UK: In case you need spare parts please indicate model number and part number shown in the assembly instruction.

F: Dans le cas où vous auriez besoin de pièces détachées, nous vous prions de bien vouloir indiquer la référence du produit et celle de la pièce en question.

SE: Om det blir nödvändigt att beställa reservdelar, var vänlig uppgi både modellnummer och det angivna numret på reservdelen.

ES: En caso de que usted necesite alguna pieza de cambio, por favor, indicar modelo y número conforme aparece en las instrucciones.

I: Nel caso in cui siano necessarie delle parti di ricambio, indicare il numero del modello e il numero della parte indicati nelle istruzioni di montaggio.

1

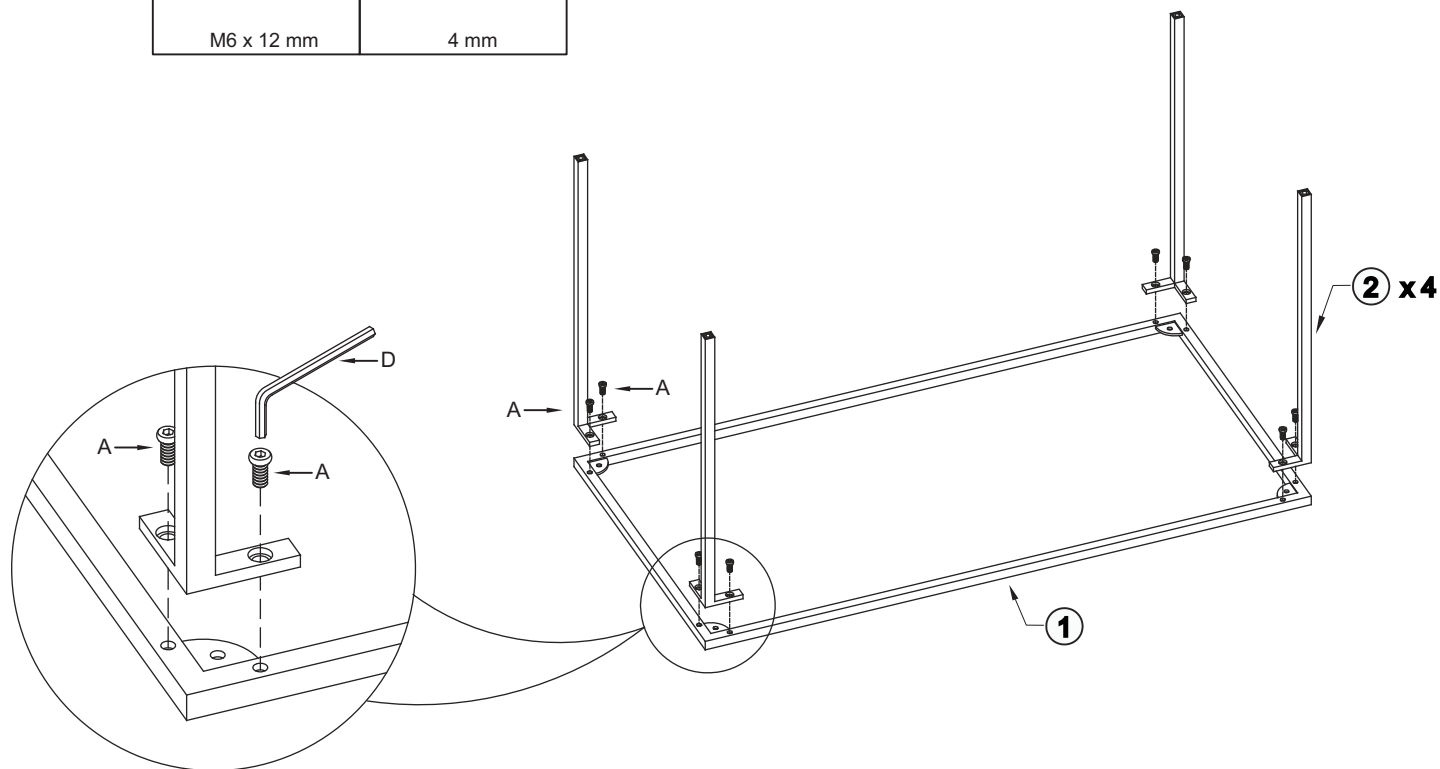
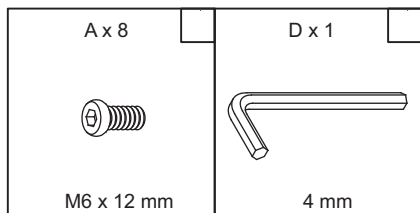

2

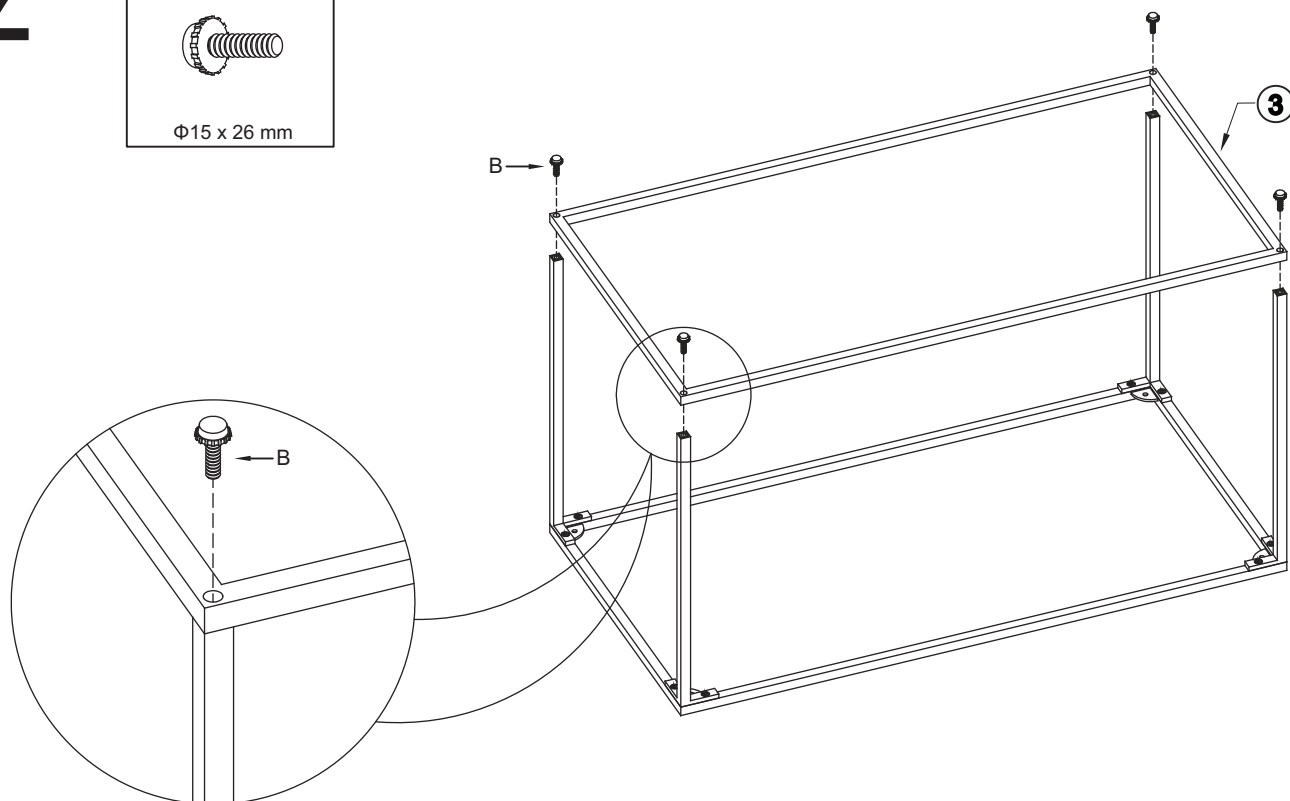
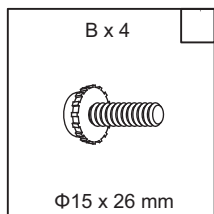

3



4

