

# RIFF

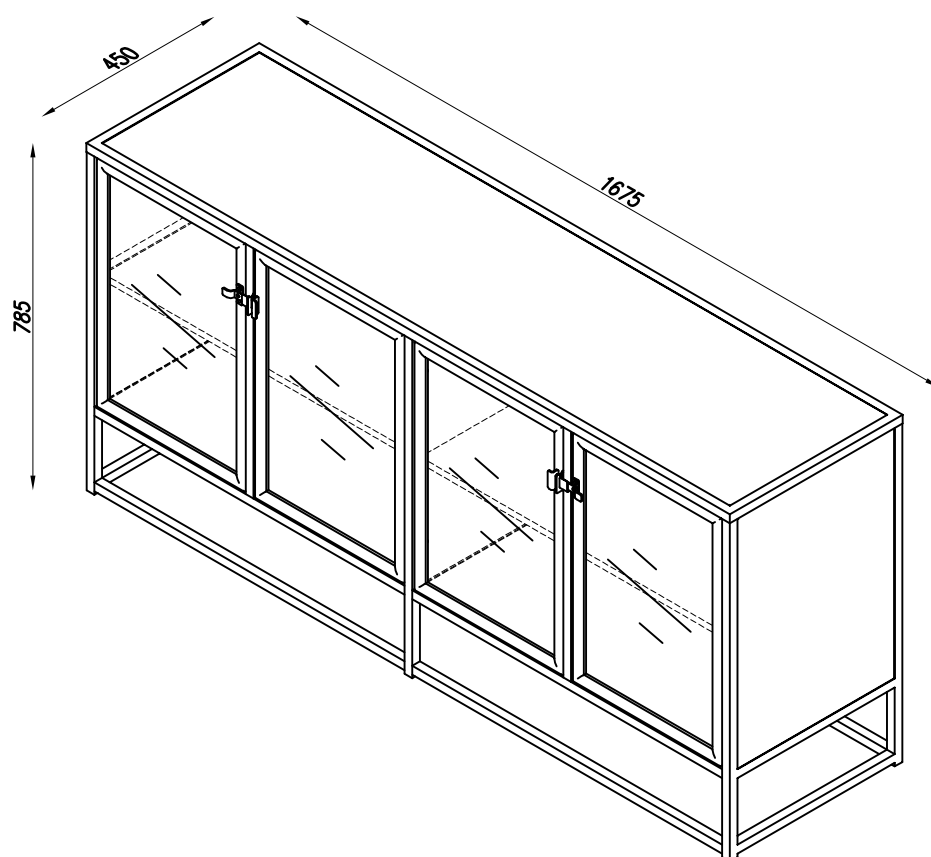

- N: Viktig; Les nøye og oppbevar for bruk senere.
- D: Wichtig! Sorgfältig lesen und für spätere Verwendung aufbewahren.
- UK: Important! Read carefully and retain for future reference.
- F: Important! A lire soigneusement et à conserver.
- SE: Viktigt : Läs noggrant och spara för senare behov.
- ES: Importante. Leer cuidadosamente las instrucciones y guardar para futuras referencias.
- I: Importante! Leggere attentamente e conservare per future necessità.

N: For å unngå at møbelet får skader under montering anbefales det å montere møbelet på et mykt underlag, f.eks. på et teppe.

UK: Assembling of the furniture should take place on a soft surface e.g.a carpet in order to avoid scratching during assembly.

D: Um zu vermeiden, dass das Möbelstück gerissen wird, empfehlen wir unbedingt, es auf einer weichen Unterlage zu montieren - z.B. ein Teppich.

F: Afin d'éviter les rayures lors du montage, l'assemblage du meuble doit être effectué sur une surface douce - par exemple une couverture.

SE: För att möbelen inte ska repas vid montering bör den monteras på ett mjukt underlag - tex. på en matta.

ES: El montaje del sofa tiene que ser hecho en una superficie suave, como por ejemplo una alfombra o una manta, para evitar rozaduras durante el montaje.

I: Il montaggio dei mobili dovrebbe essere eseguito su una superficie morbida, ad esempio su un tappeto, per evitare rigature dovute all'assemblaggio.

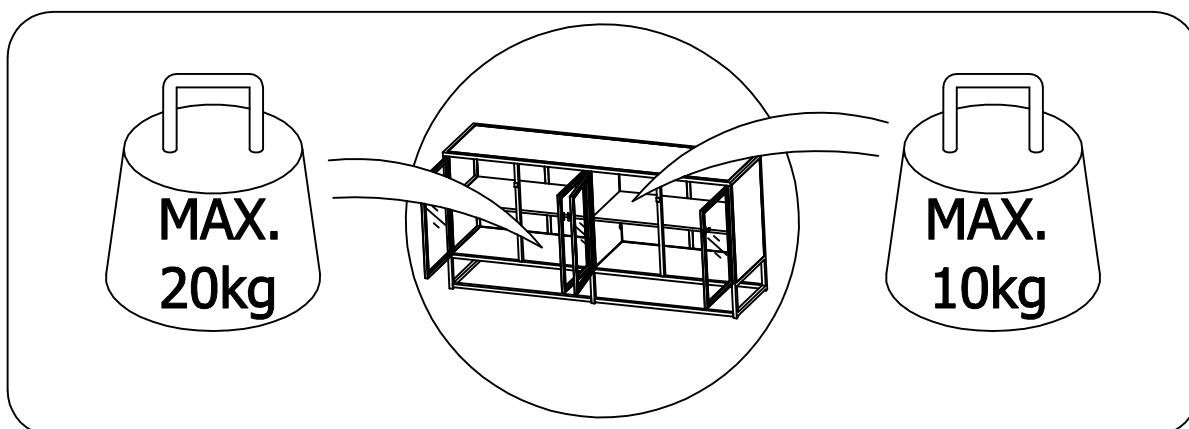
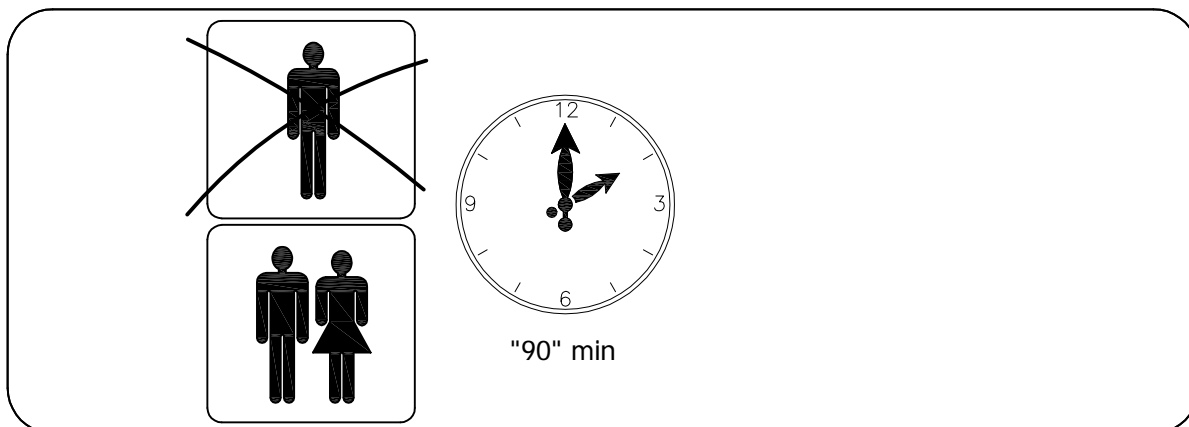
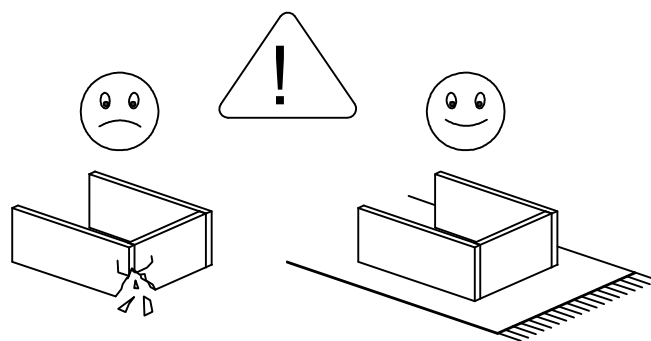

ID nr. 5115



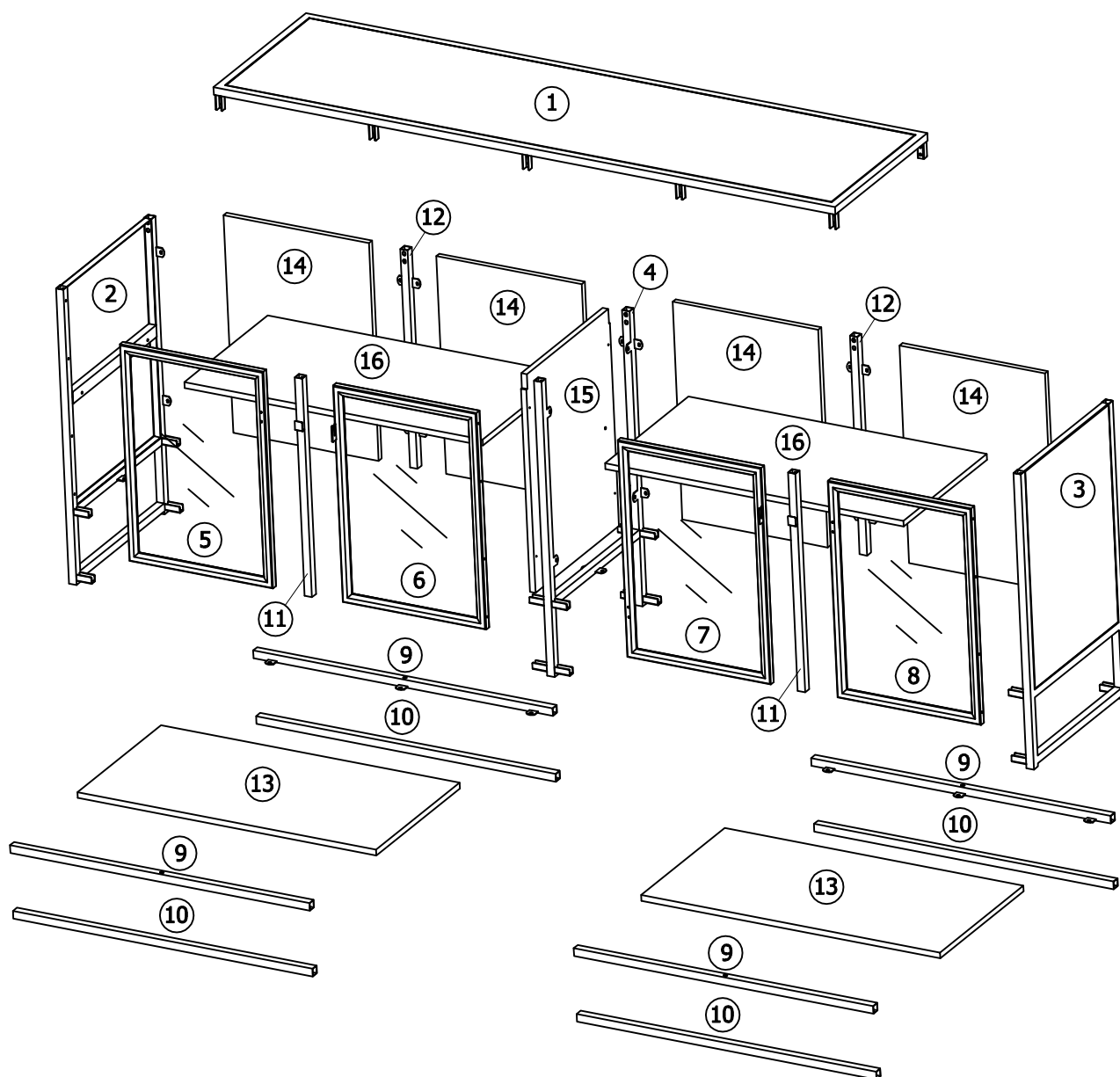

			✓
1	1	1675x450x60	1/3
2	1	765x449x60	1/3
3	1	765x449x60	1/3
4	1	765x449x100	1/3
5	1	560x386.5x18	2/3
6	1	560x386.5x34	2/3
7	1	560x386.5x34	2/3
8	1	560x386.5x18	2/3
9	4	807x41x20	1/3
10	4	807x20x20	1/3
11	2	565x29x20	1/3
12	2	565x62x20	1/3
13	2	805x407x15	3/3
14	4	563x392x15	3/3
15	1	563x407x15	3/3
16	2	804x406x15	3/3



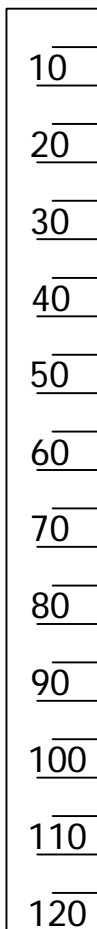

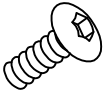
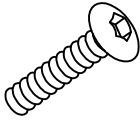
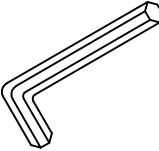
mm

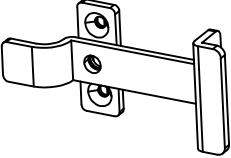

<p>A x 52</p>  <p>Ø6x14mm</p>	<p>B x 4</p>  <p>Ø6x35mm</p>	<p>C x 1</p>  <p>4mm</p>	<p>D x 36</p>  <p>Ø4.0x13mm</p>
<p>E x 20</p>  <p>M4x12mm</p>	<p>F x 2</p>  <p>86x41x18mm</p>	<p>G x 8</p>  <p>M5/Ø6x17mm</p>	<p>H x 4</p>  <p>Ø8x2mm</p>

N: Dersom det skulle være nødvendig å bestille reservedeler, vennligst oppgi både modell- og delenummer.

D: Falls Sie Ersatzteile benötigen, geben Sie bitte Modellnummer und Teilnummer, die Sie in der Montageanleitung findet an.

UK: In case you need spare parts please indicate model number and part number shown in the assembly instruction.

F: Dans le cas où vous auriez besoin de pièces détachées, nous vous prions de bien vouloir indiquer la référence du produit et celle de la pièce en question.

SE: Om det blir nödvändigt att beställa reservdelar, var vänlig uppgi både modellnummer och det angivna numret på reservdelen.

ES: En caso de que usted necesite alguna pieza de cambio, por favor, indicar modelo y número conforme aparece en las instrucciones.

I: Nel caso in cui siano necessarie delle parti di ricambio, indicare il numero del modello e il numero della parte indicati nelle istruzioni di montaggio.

# 1

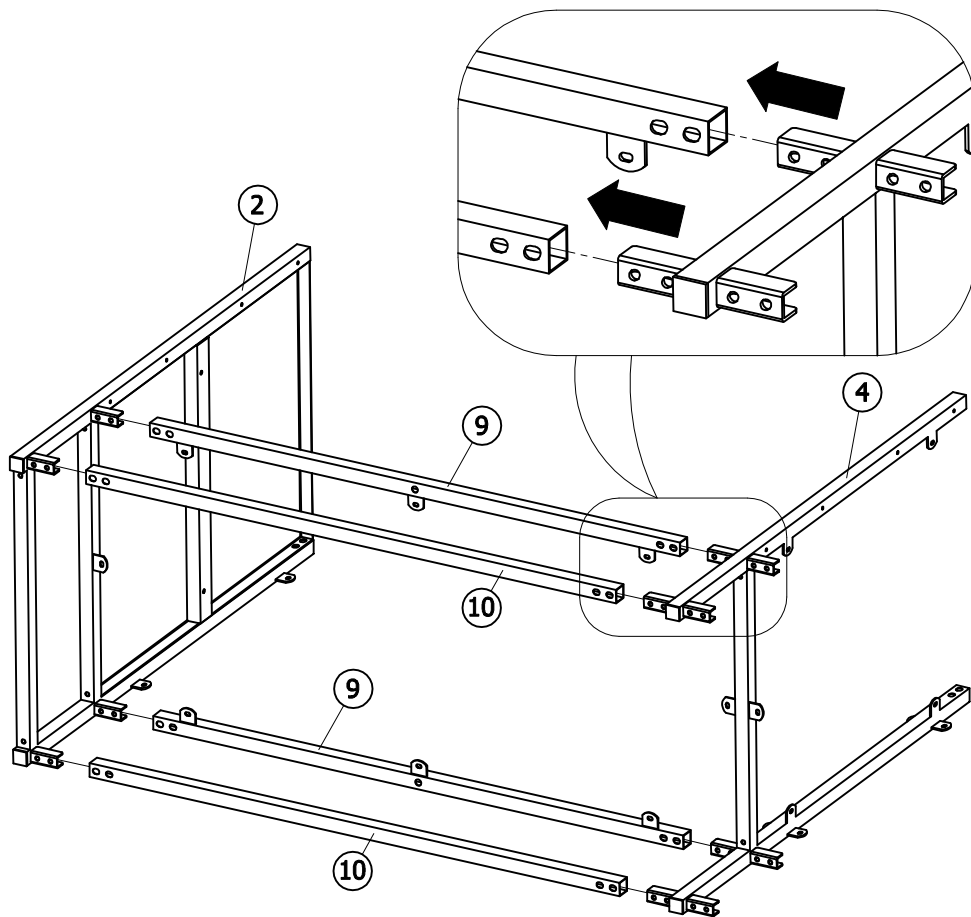

# 2

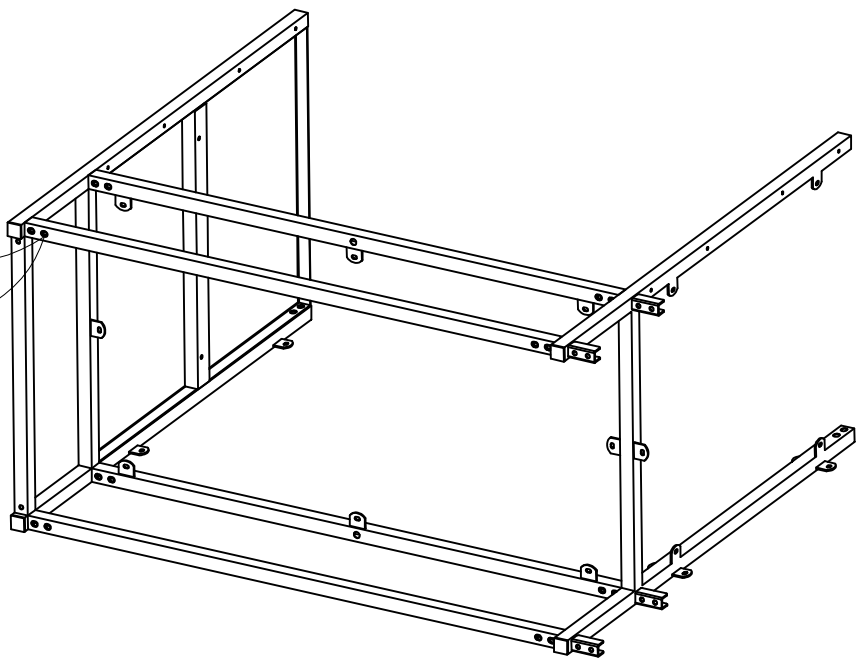
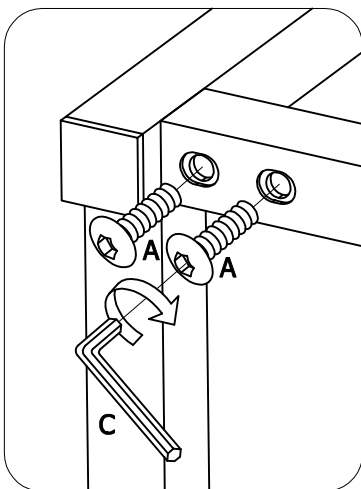
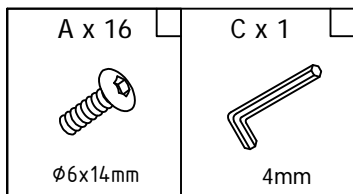

Trekk til skruene ca 80% slik at stangen fortsatt kan beveges.

# 3

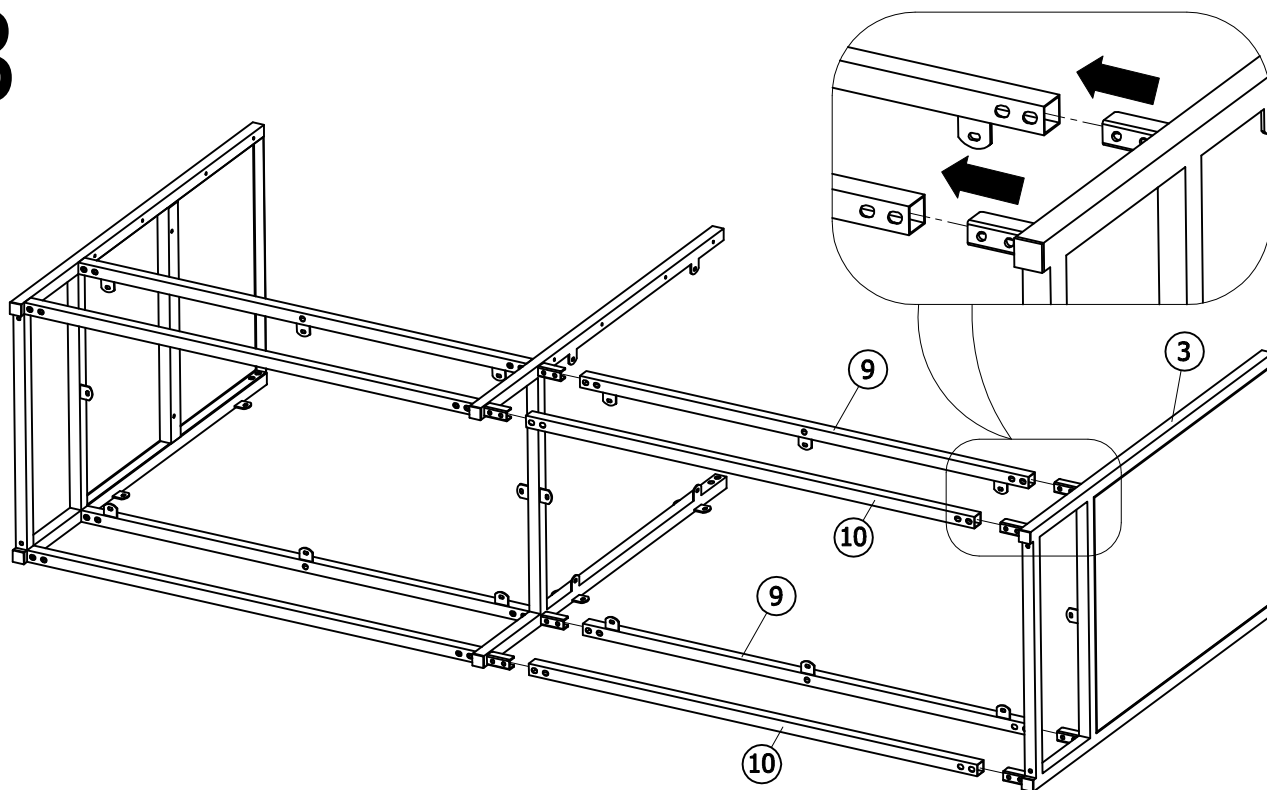

# 4

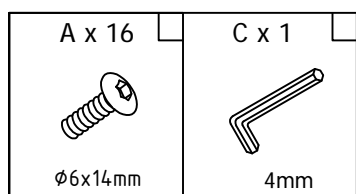

Trekk til skruene ca 80% slik at stangen fortsatt kan beveges.

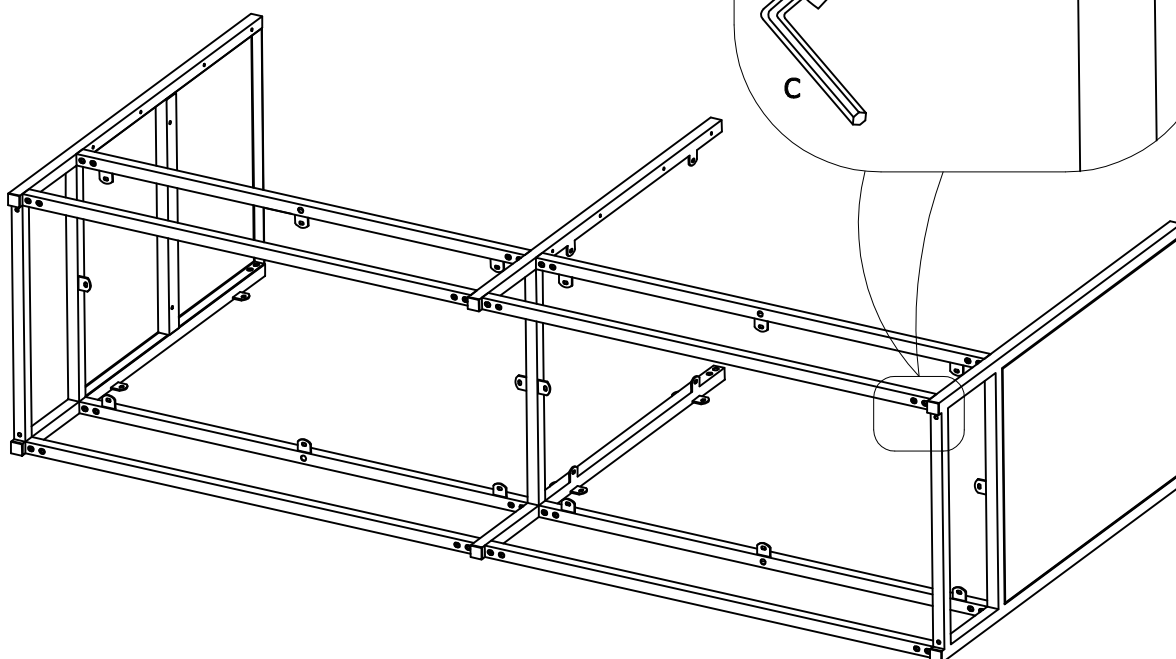

# 5

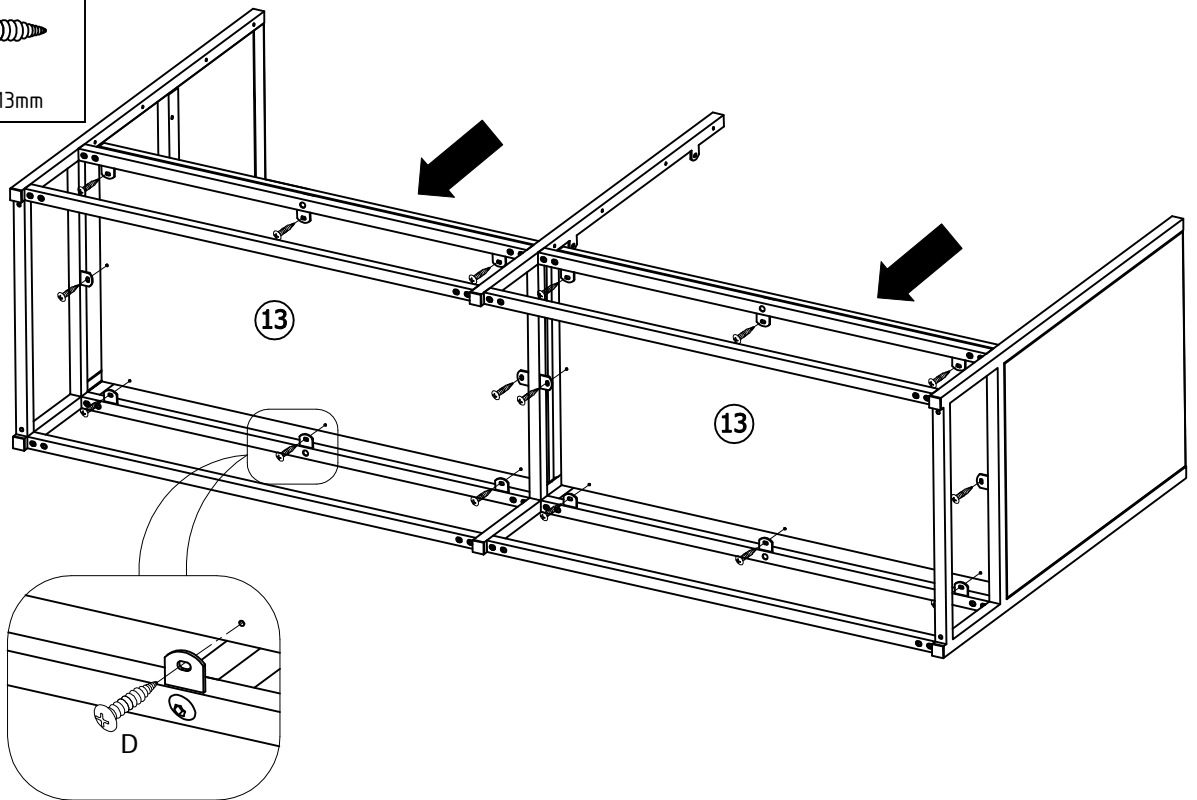
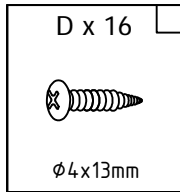

# 6

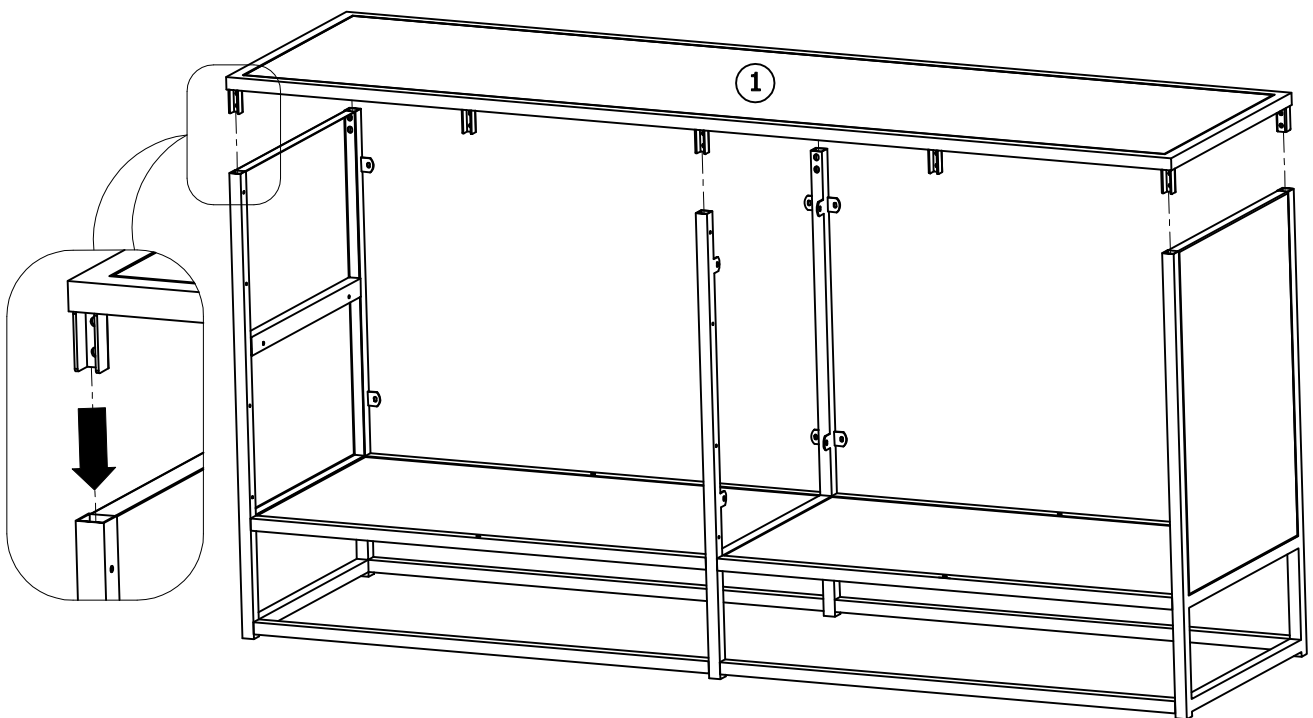

# 7

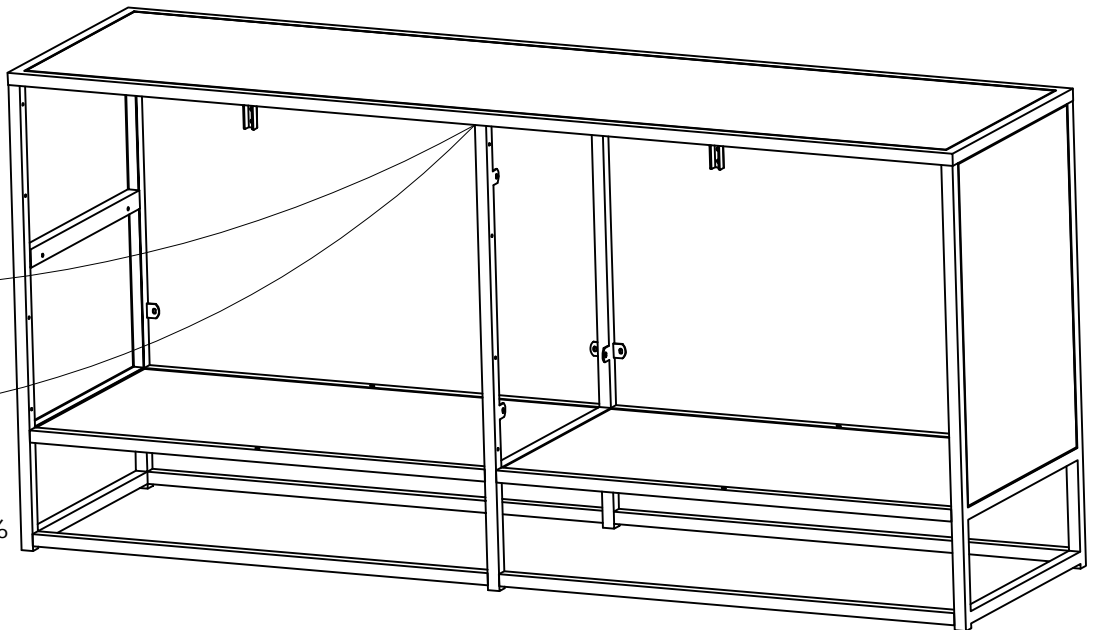
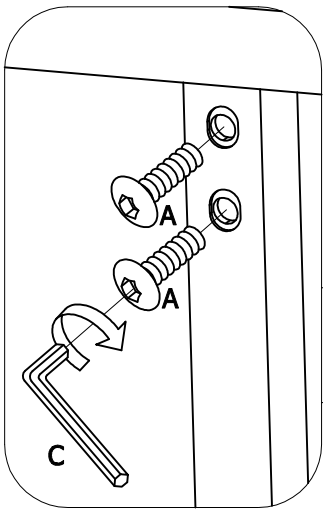
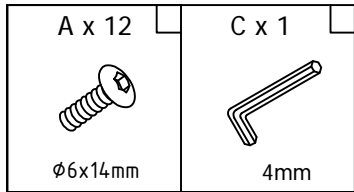

Trekk til skruene ca 80% slik at stangen fortsatt kan beveges.

# 8

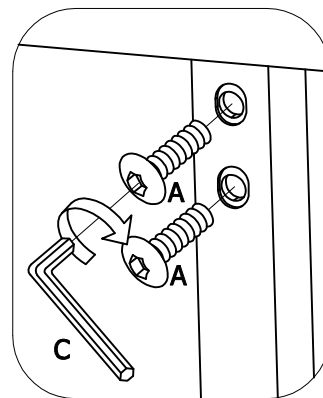
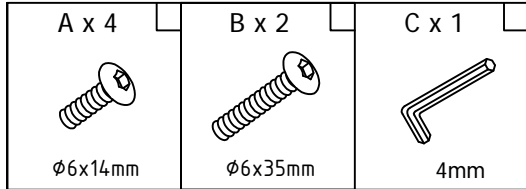

Trekk til skruene ca 80% slik at stangen fortsatt kan beveges.

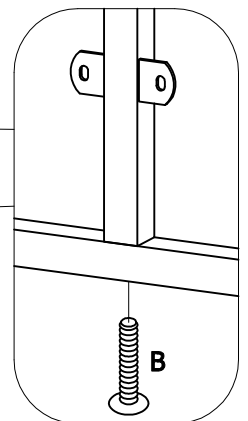
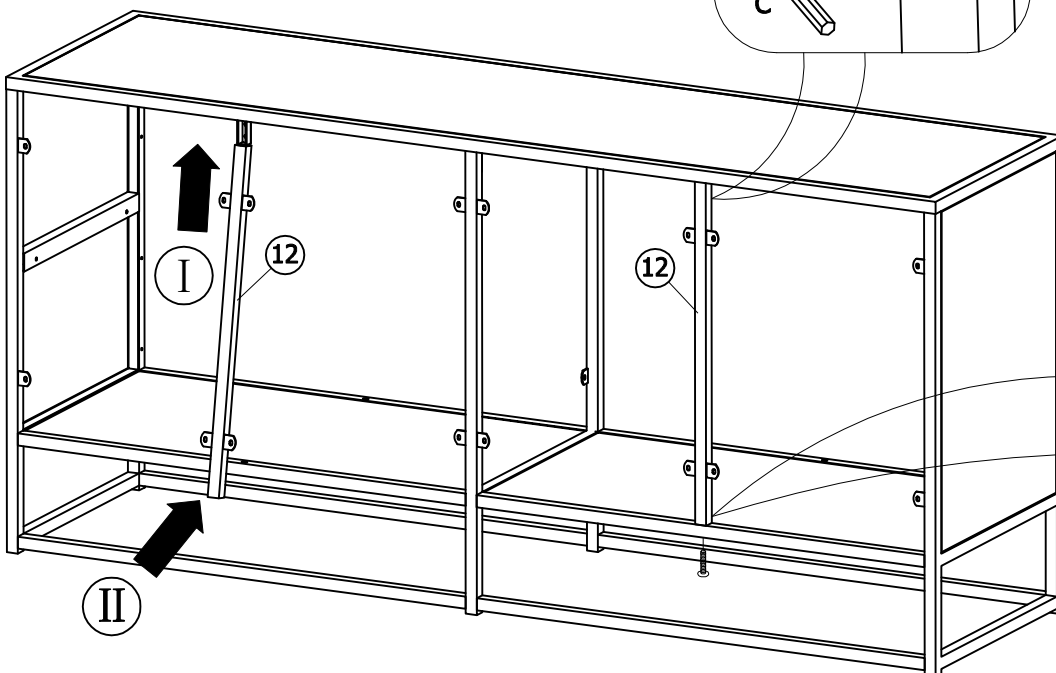



# 9

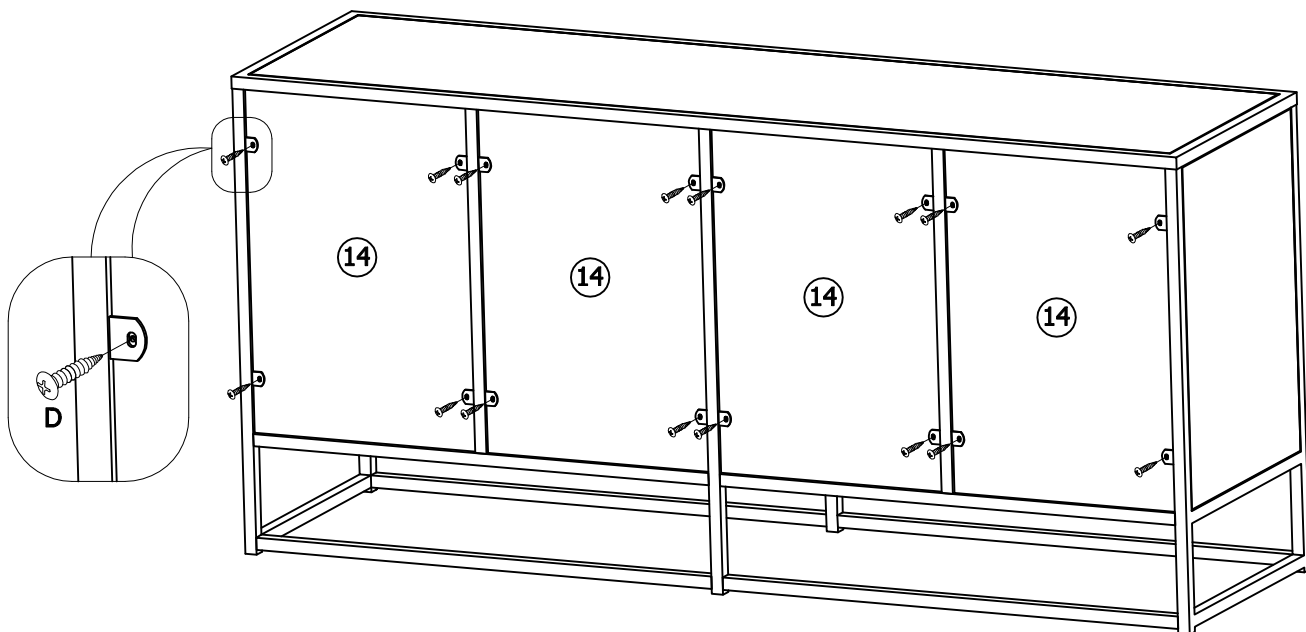
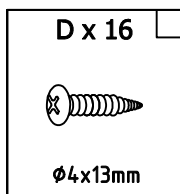

# 10

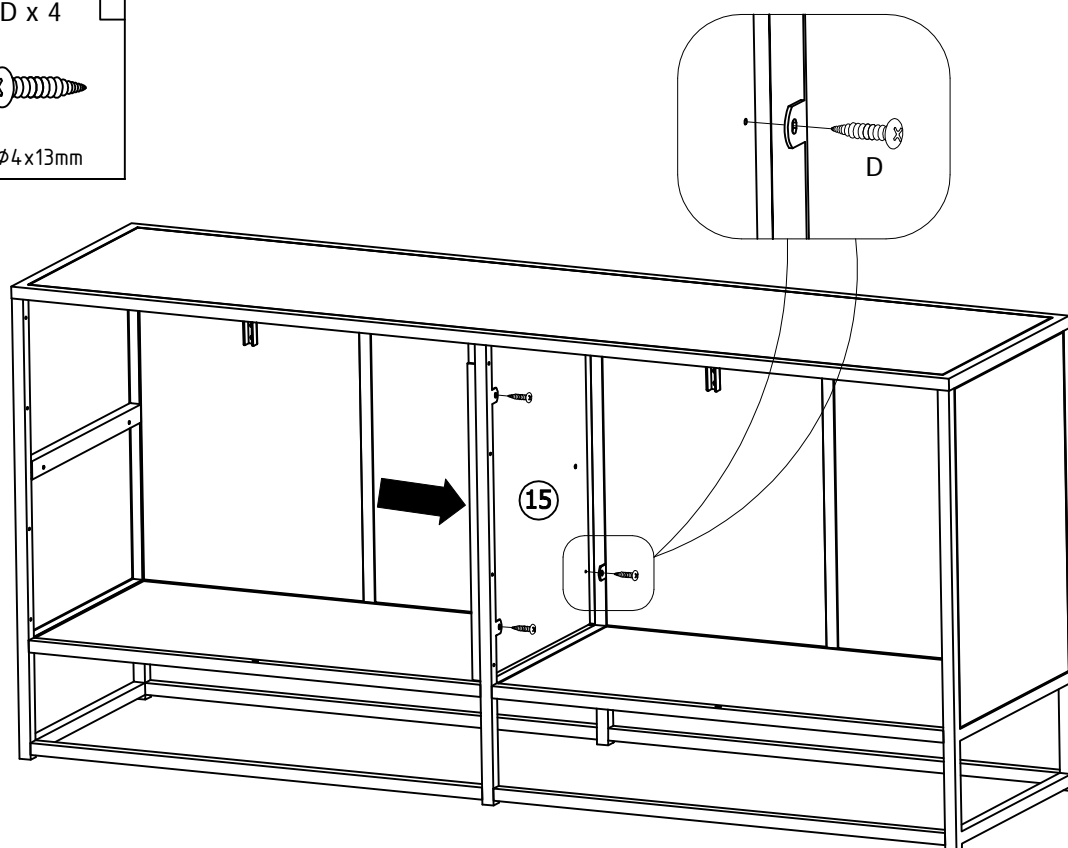
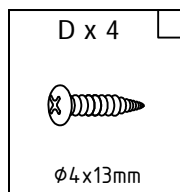

# 11

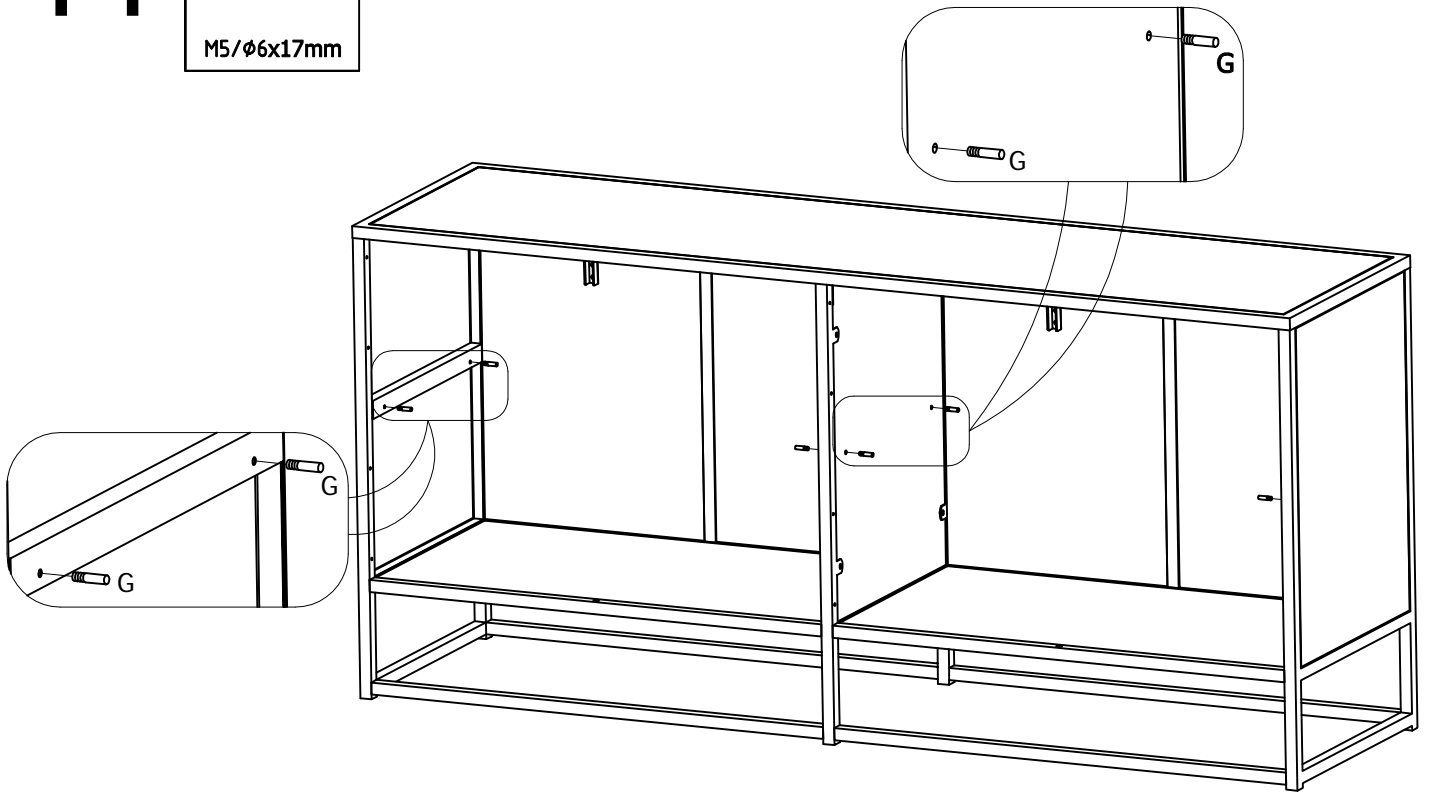
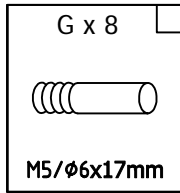

# 12

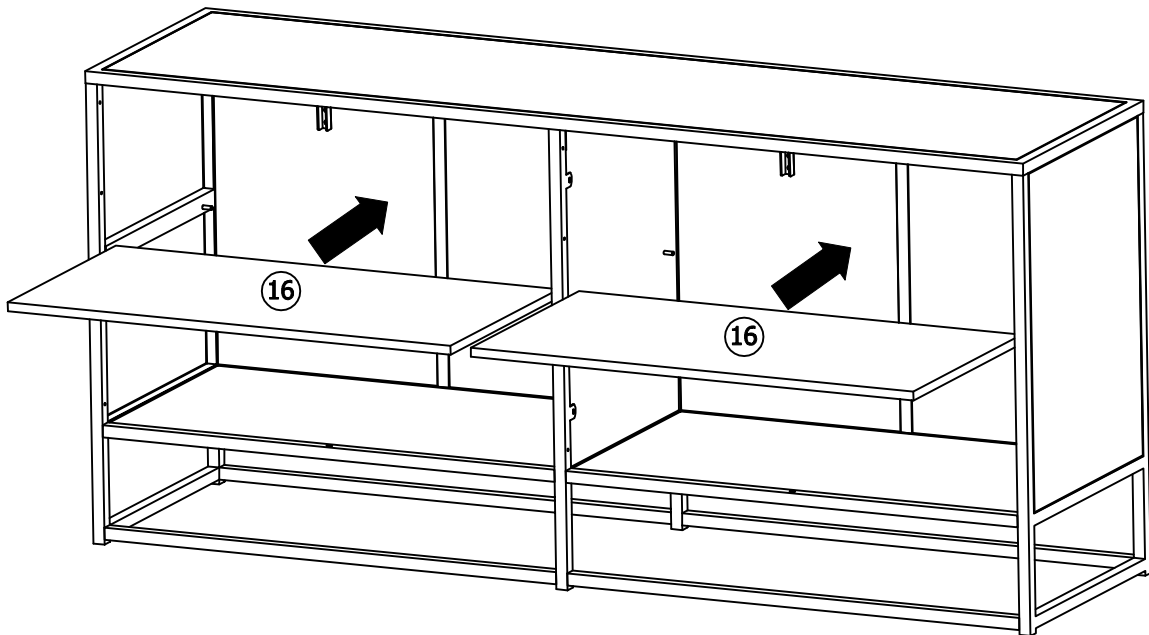

# 13

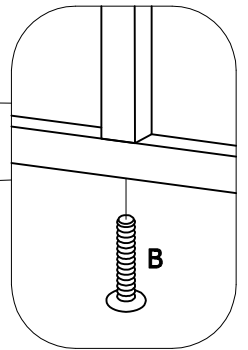
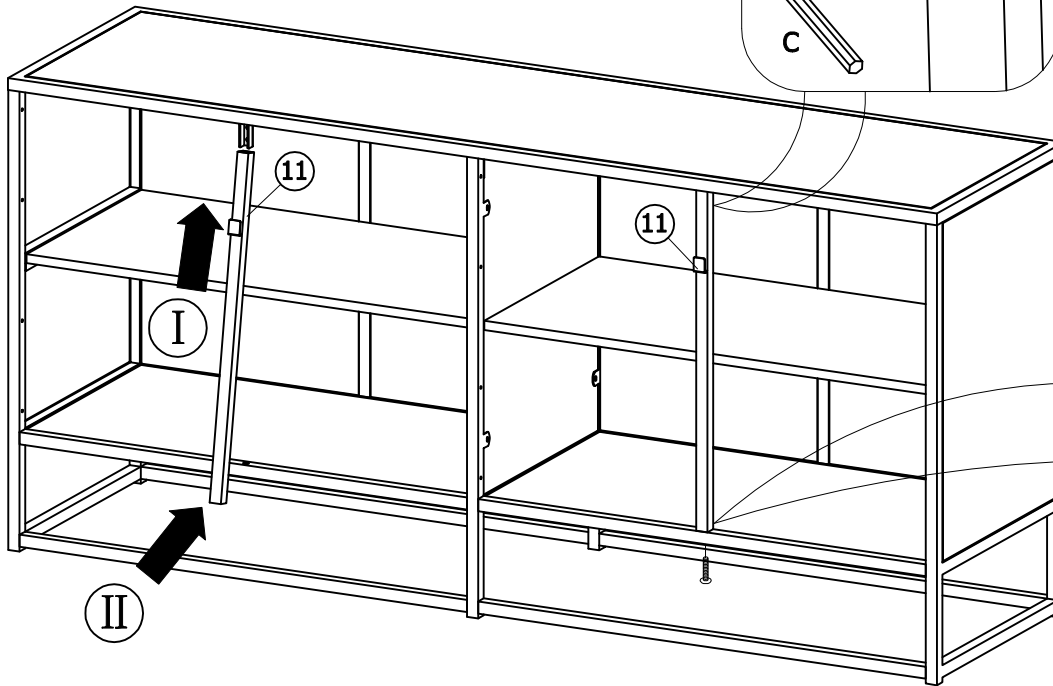
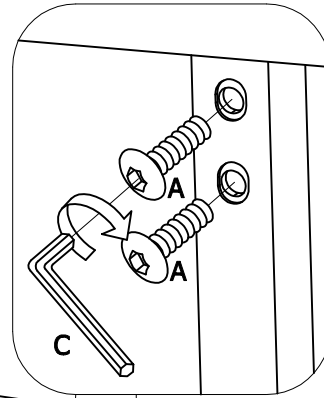
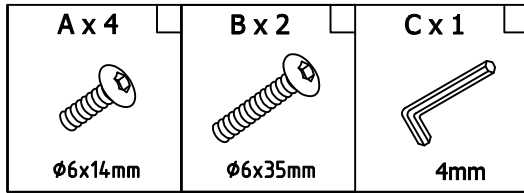

# 14

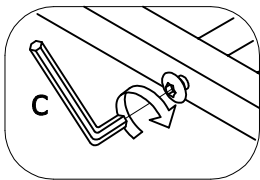
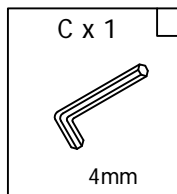

Nå strammes alle skruer 100%.

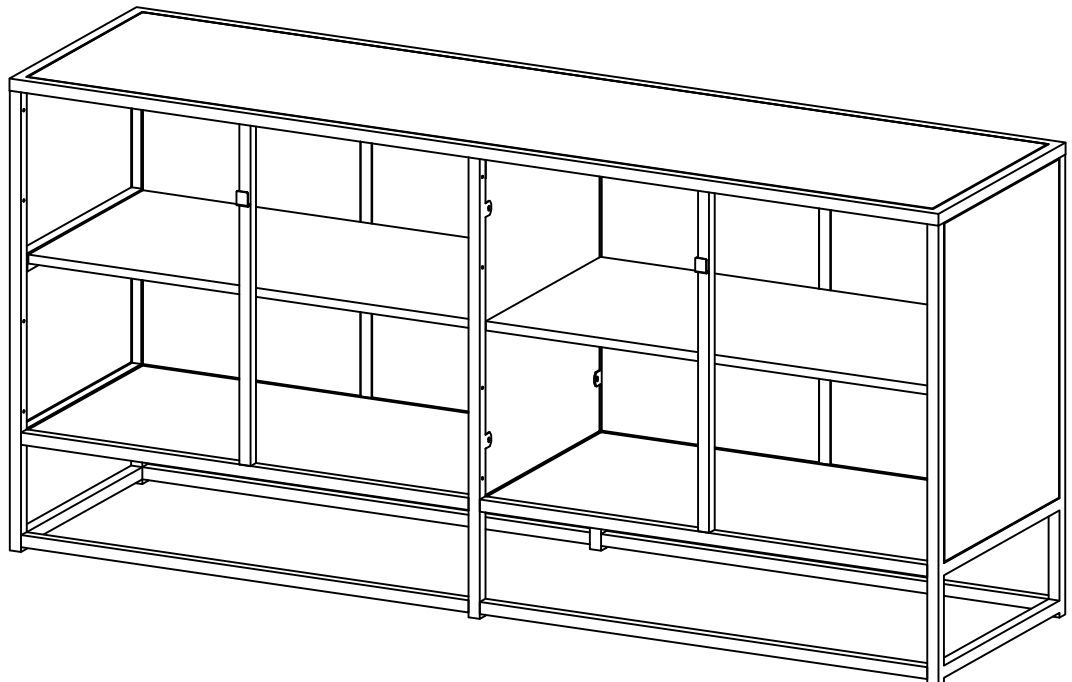

# 15

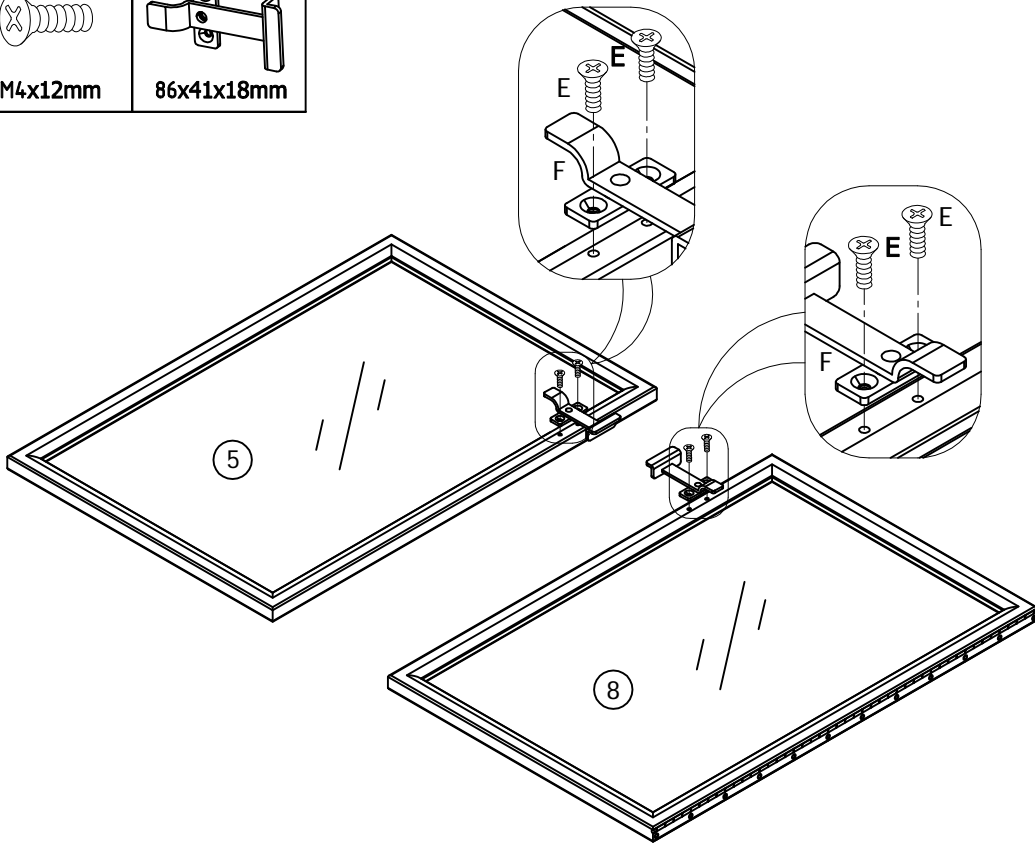
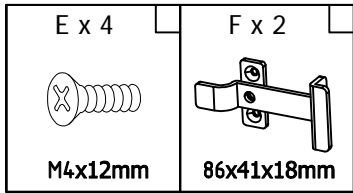

# 16

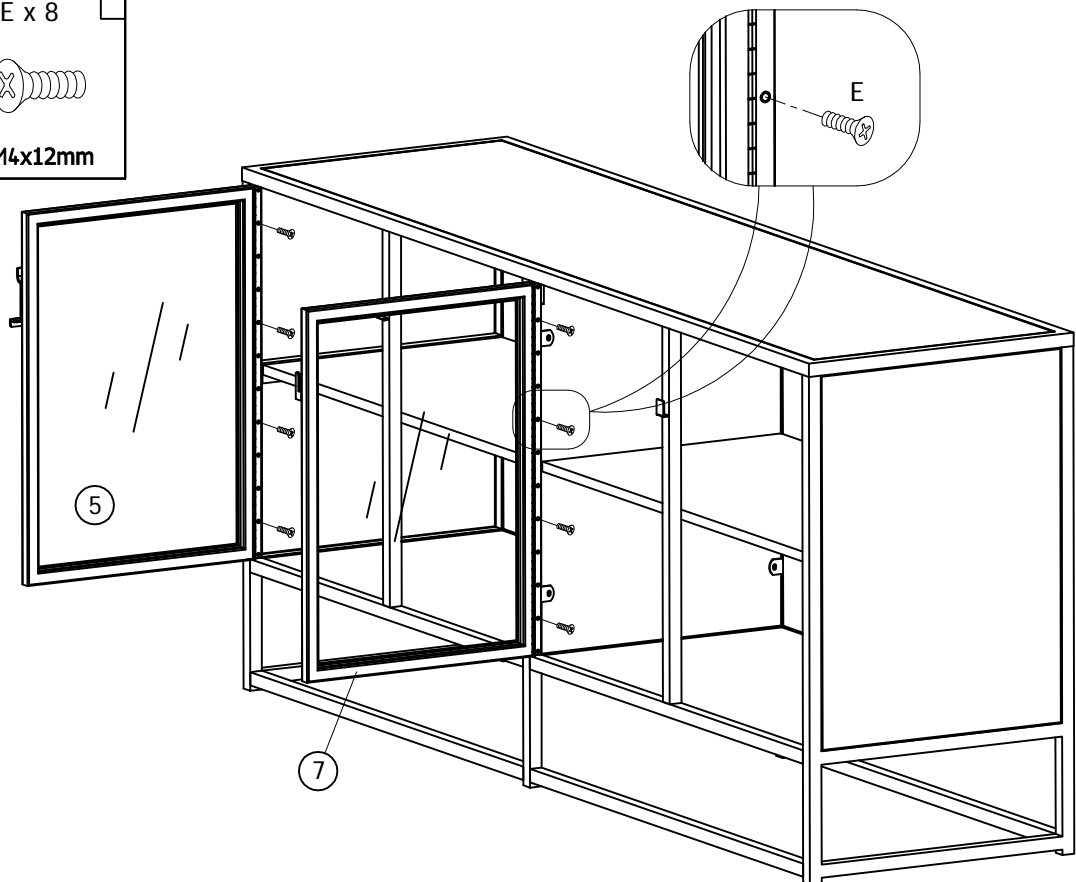
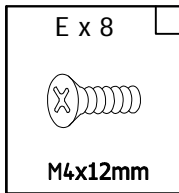

# 17

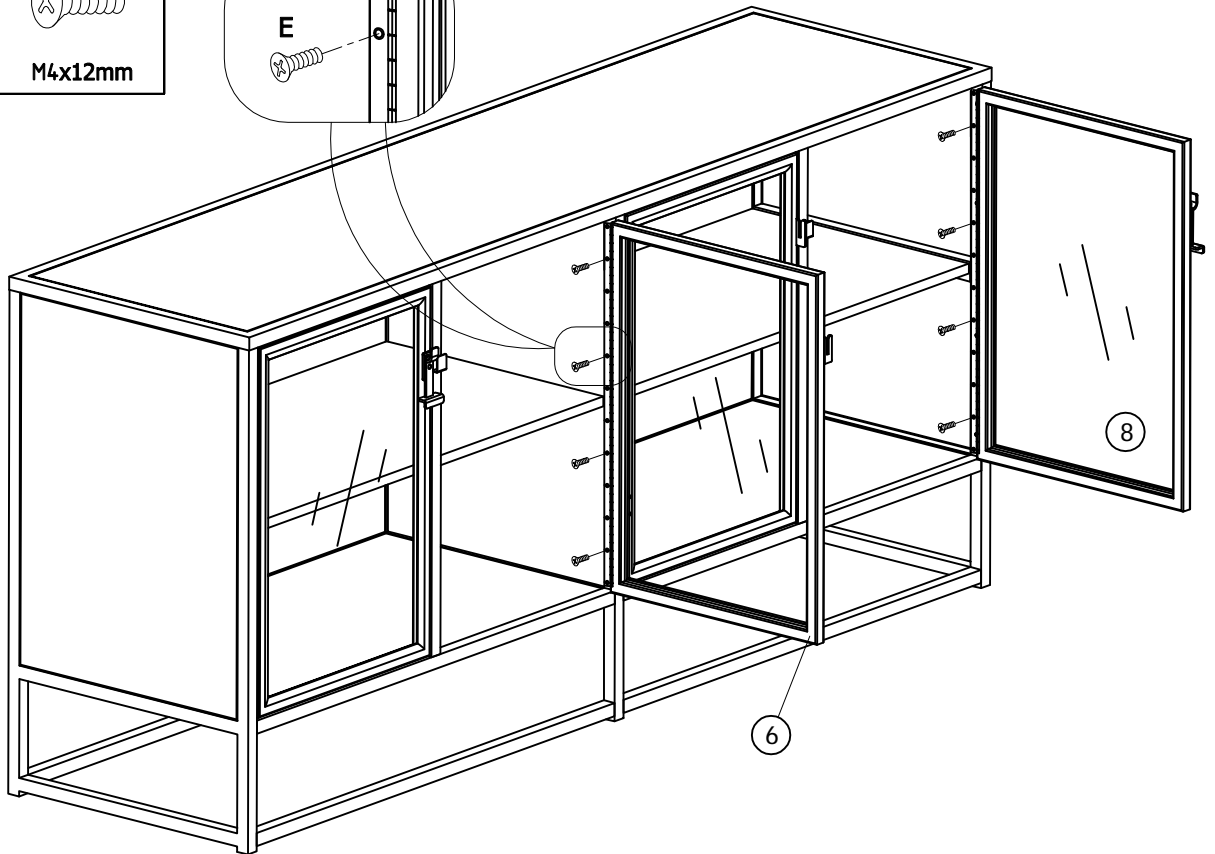
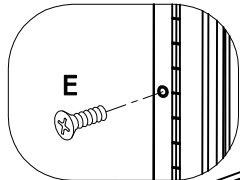
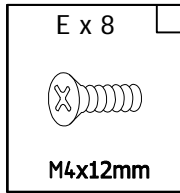

# 18

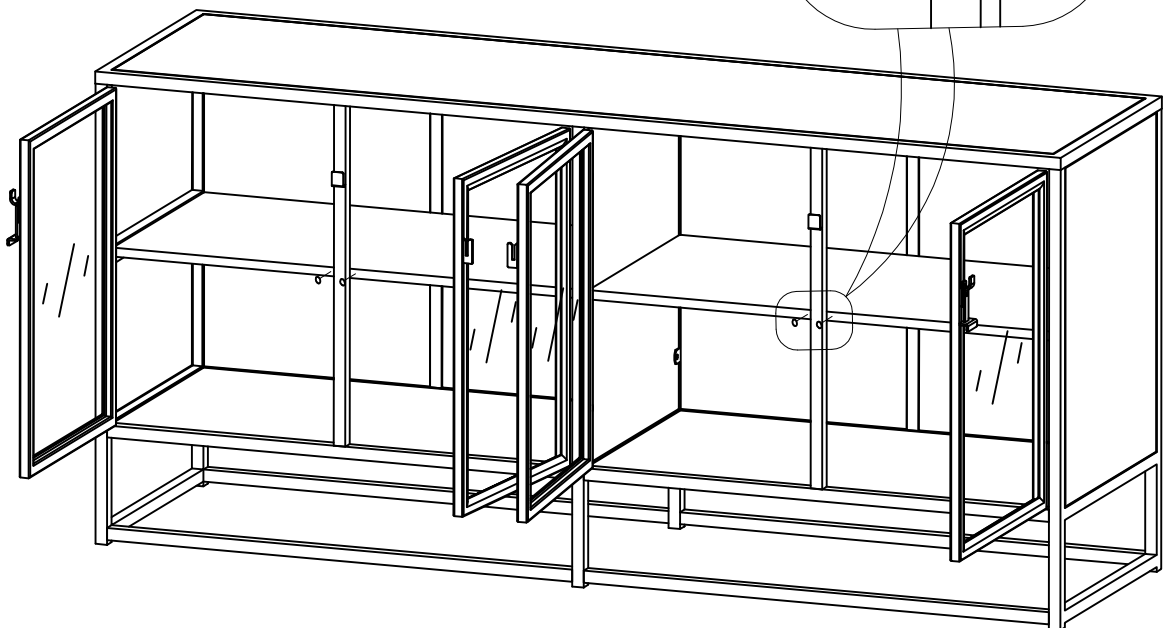
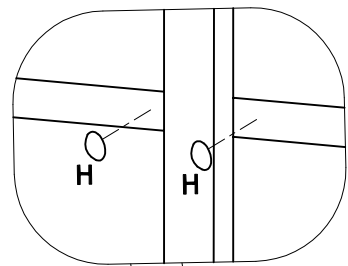
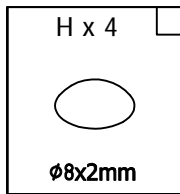

19

