

# Assembly instruction

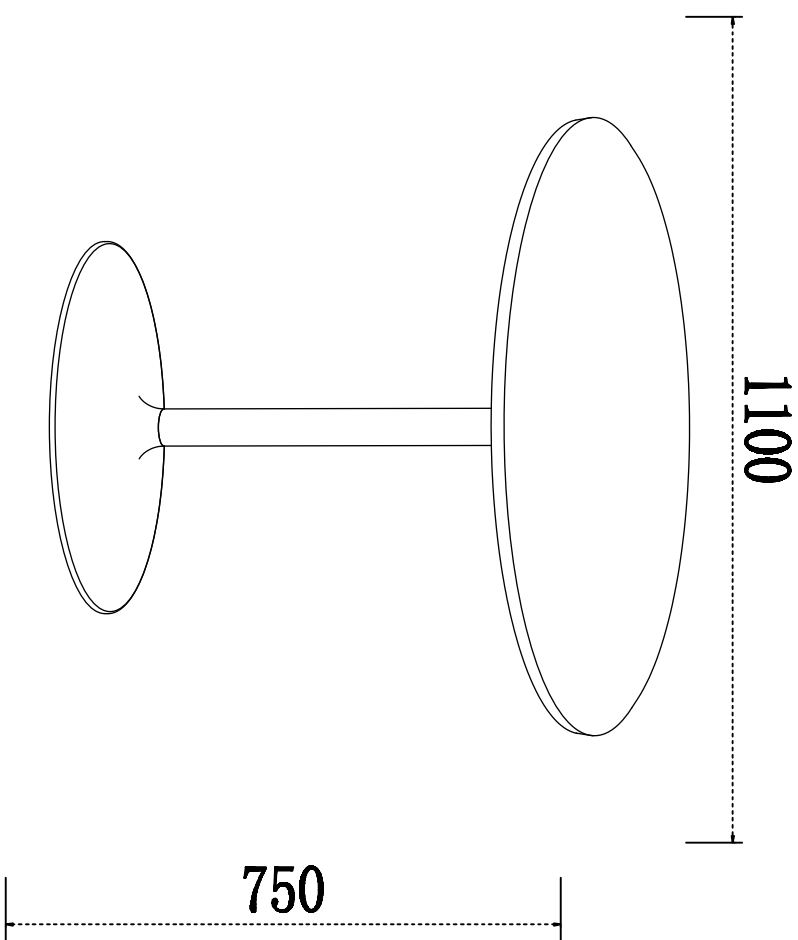

## Hardware list

A		1	ø12*140	Screw
B		1	ø12*90	Screw
C		4	ø8*20	Screw
D		2	ø12	Spring washer
E		1	ø12	Flat washer
F		4	ø8	Flat washer
G		1	ø12	Flat washer
H		1	M10	Allen key
I		1	M5	Allen key

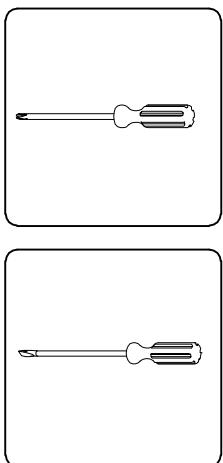
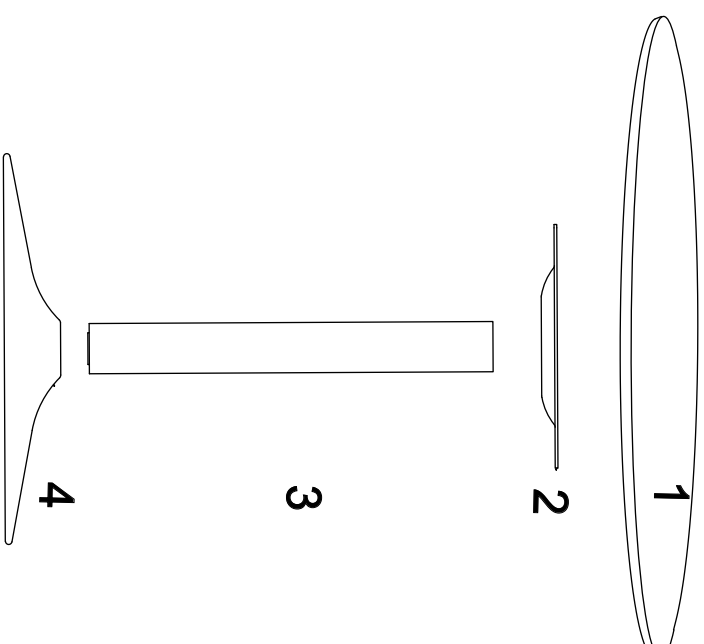

# Step1

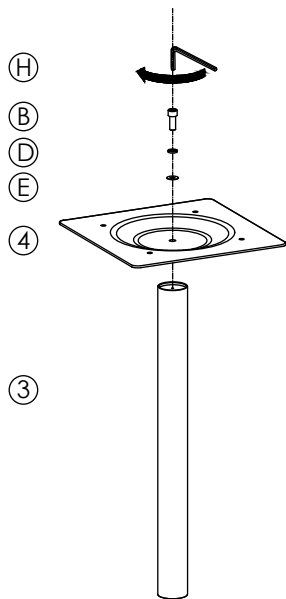

# Step2

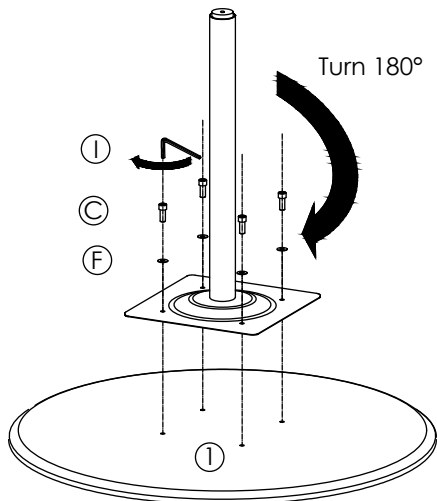

# Step3

