

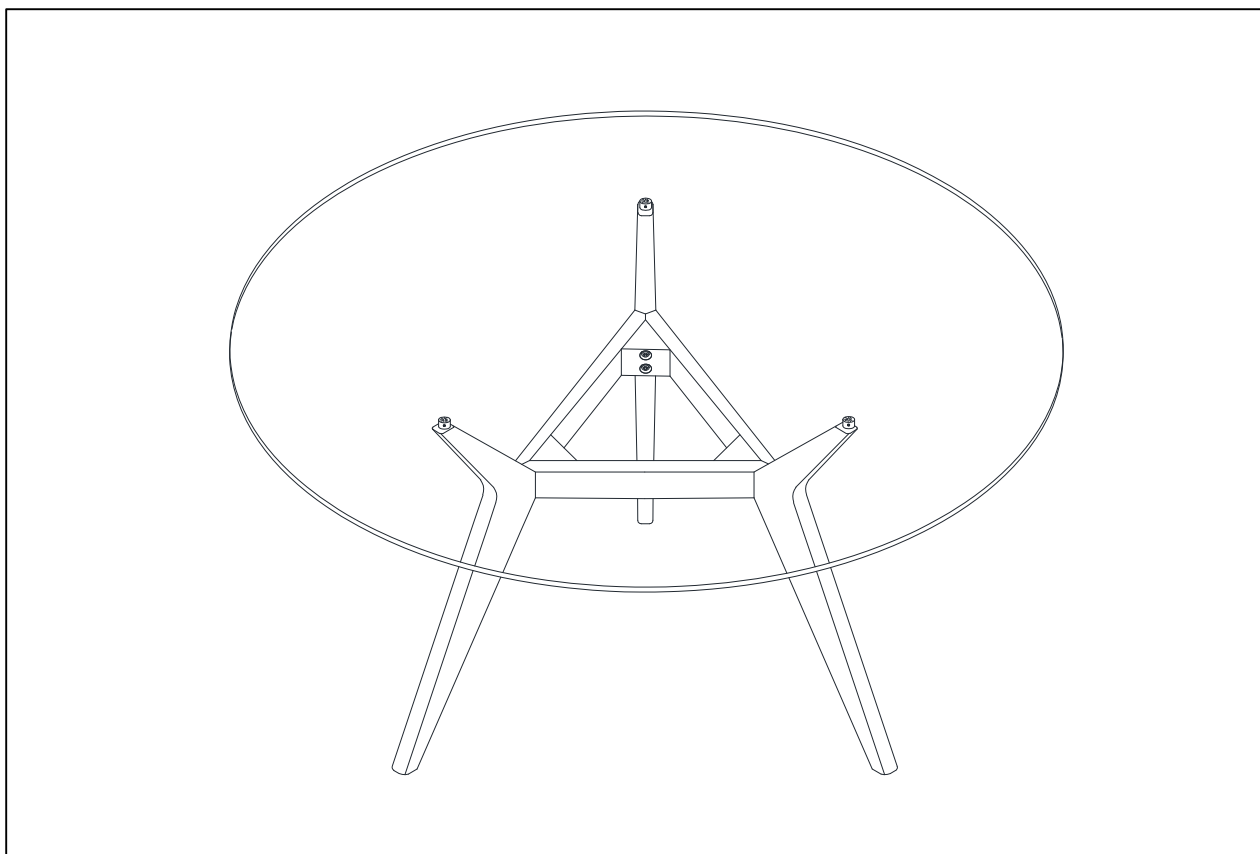

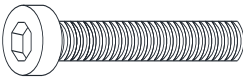

ASSEMBLY INSTRUCTIONS

1597640-01

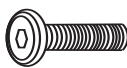
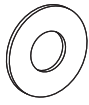

HARDWARE			TOOL REQUIRED		
					
M 8 x 80 mm A x 6	M 6 x 16 mm B x 6	M 8 x 16 mm C x 6	5 mm D x 1	4 mm E x 1	2 mm F x 1

COMPONENTS

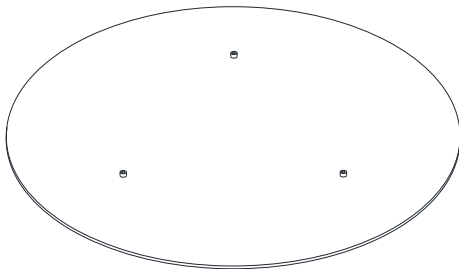

G x 1

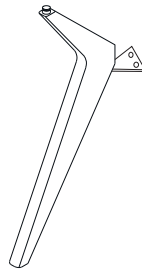

H x 3

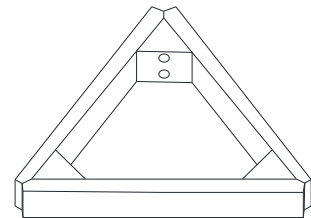

I x 1

ASSEMBLY INSTRUCTION

STEP: - 1

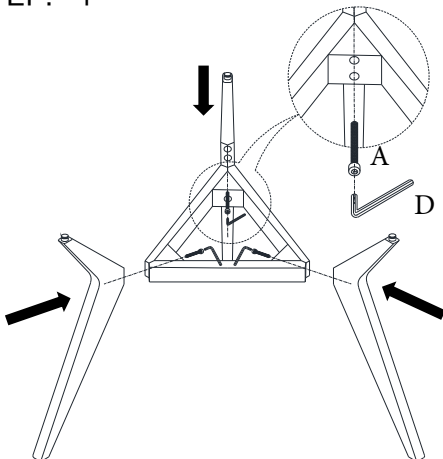

STEP: - 2

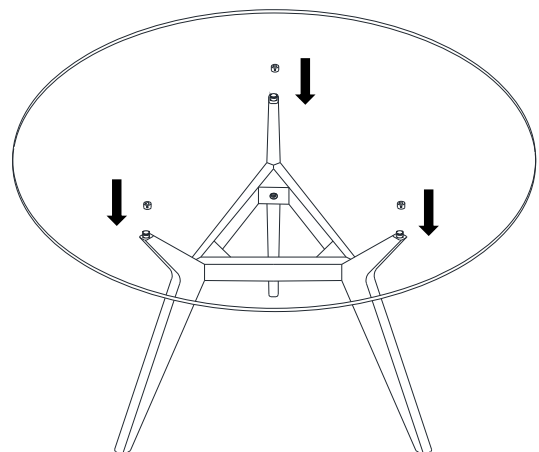

STEP: - 3

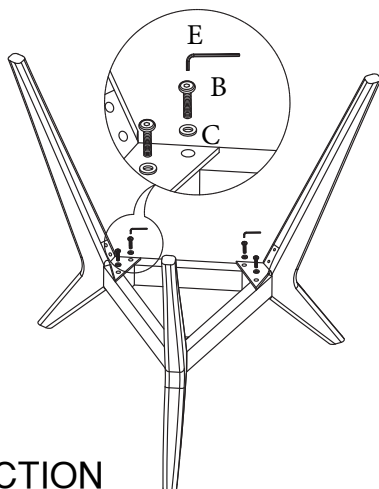

STEP: - 4

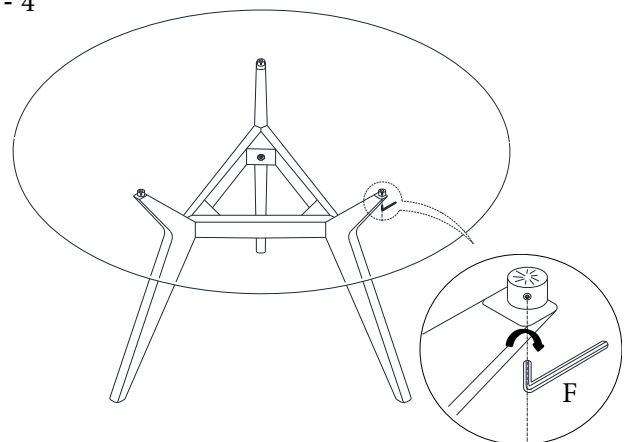

INSTRUCTION

- A. Remove all parts from the carton and separate them into part number groups as indicated in the part list/ place the product upside down.
- B. fix the leg parts.