

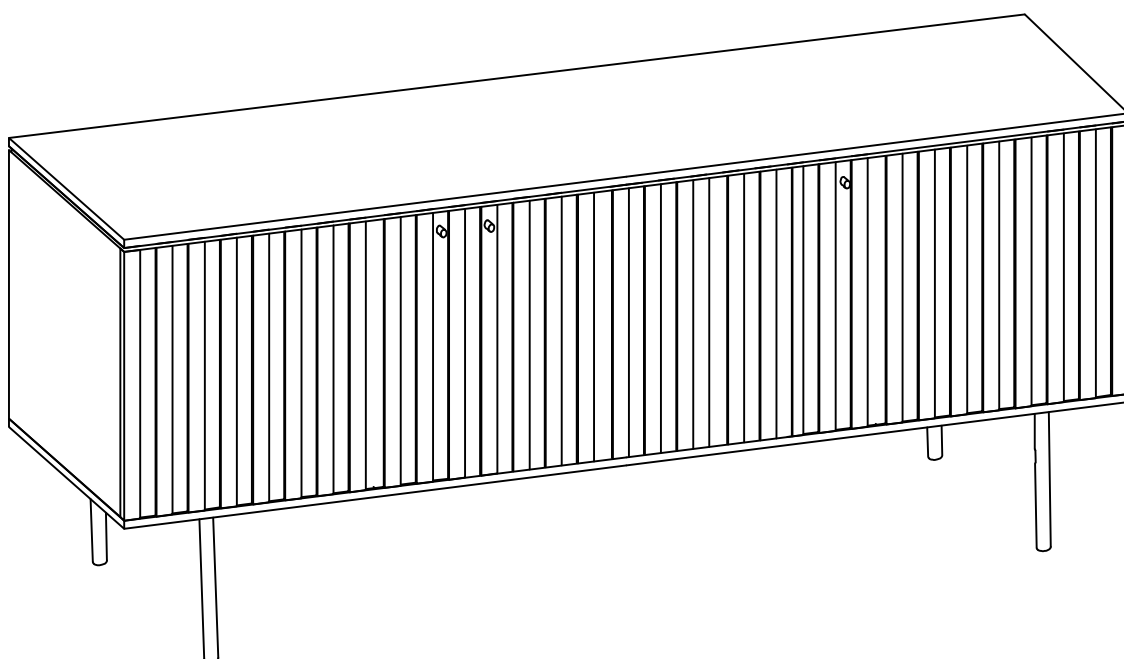

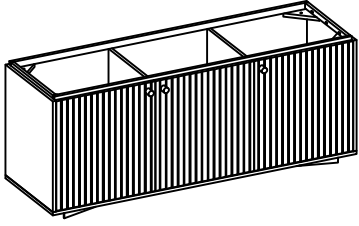

# ASSEMBLY INSTRUCTIONS



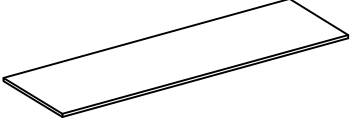

## 1597642-01



# Component List

Label	Picture	Description	Qty
A		Sideboard Body	1
B		Leg	4
C		Marble Top	1
D		Shelves	3

## Hardware List

Label	Picture	Description	Qty
H1		Small Allen Bolt 6 x 10 mm	8
H2		Small Flat Washer 6.5 x 15.5 mm	8
H3		Large Allen Bolt M6 x 30 mm	4
H4		Large Flat Washer M8 x 16 mm	4
H5		Shelf Pin	12

## Tool List

Label	Picture	Description	Qty
T1		Allen Key 4 mm	1

## Assembly Prep

Before Beginning:

\* Save all packaging until finished. 

\* Read Instructions, cover to cover. 

\* Have 2 adults on hand for assembly. 

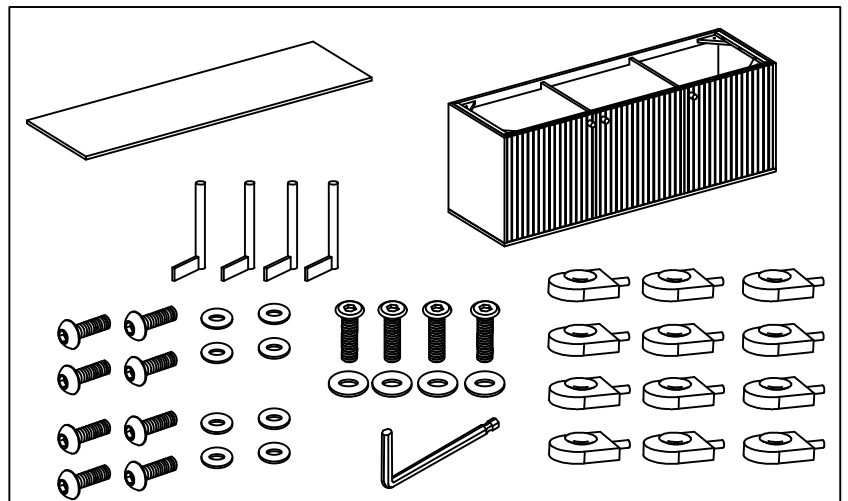

# Assembly Steps

## Step 1

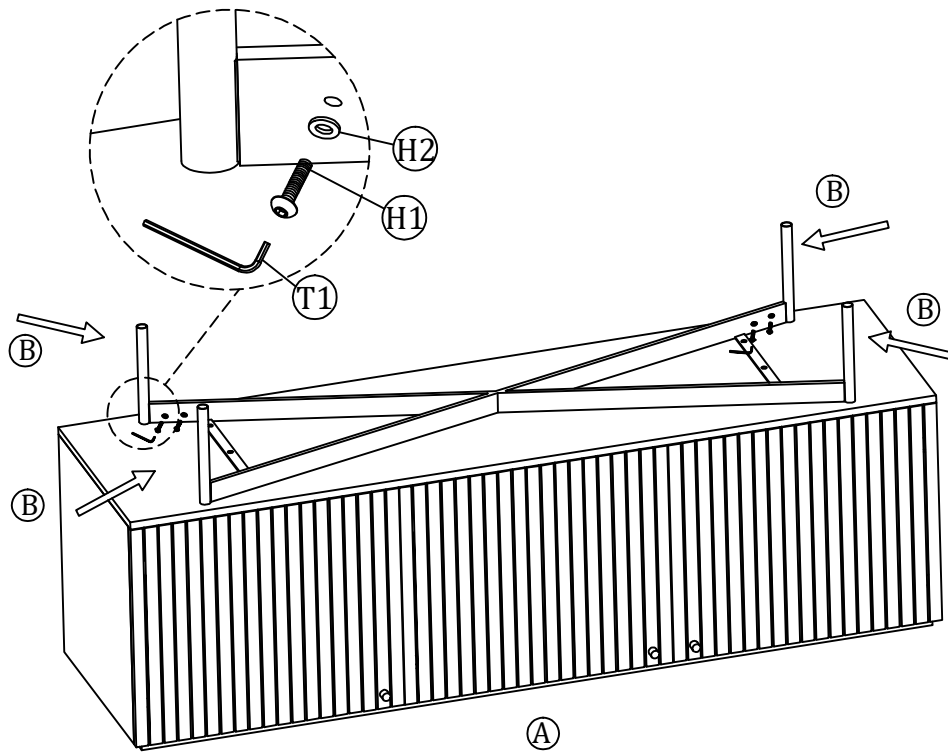

### Careful : Extremely heavy product.

Place Side Board Top (A) upside down on a non-damaging padded surface. Insert and align leg (B) into the pre-attached metal frame underneath the Side Board Top (A) and secure using 2 Allen bolt (H1) and 2 small Washer (H2). Fully tighten using Allen key (T1). Follow the same step to assemble other legs (B).

## Step 2

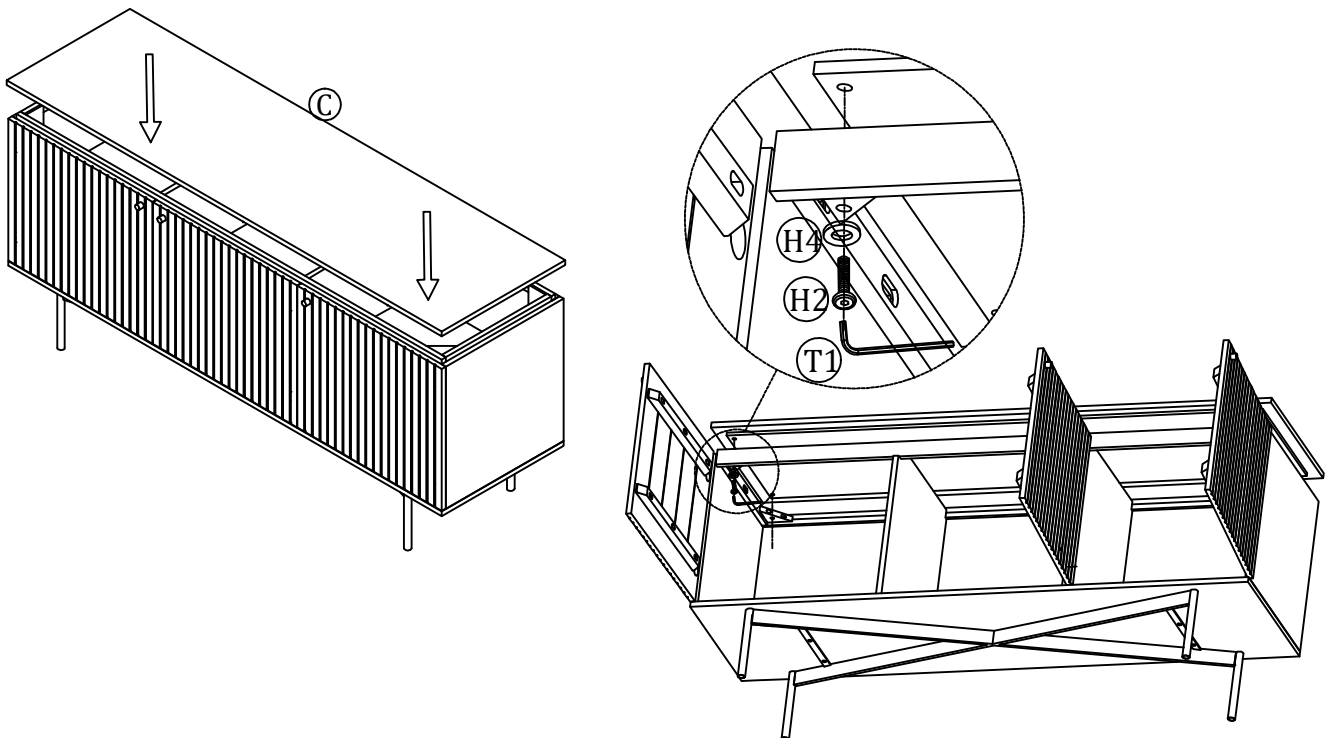

Gently place the Marble top (C) onto the top of Bar Cabinet (A+B) ensuring consistent overhang on all sides. Now accessing from the bottom side of the Bar, secure the marble top to the frame using 4 Large Allen Bolt (H3) and 4 Large Washer (H4). Once All bolts are fully engaged, tighten the bolts using the Allen key (T1).