

NE1 - ELECTRIC ADJUSTABLE DESK ART NO. : 10070

Installation guide

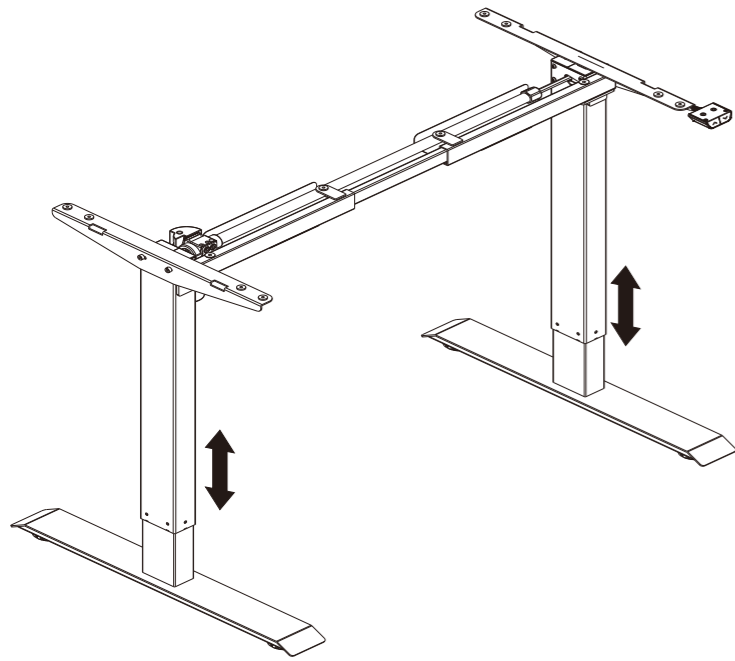

Technical data

Column Number	2
Maximum Load	70KG
Max Speed	25mm/s
Input Voltage	100-240V
Lowest Position	710mm
Highest Position	1210mm
Desktop Size	1000-1600mm 500-800mm
Duty Cycle	Continuous operation for 2 mins at most after pause for 18 mins
Applicable Temperature	0~40°C

Accessory list

Attention: The drawings below are only for reference which might be slightly different from the actual object, please in kind prevail. Any tools missing or installation problems, please contact the customer service firstly.

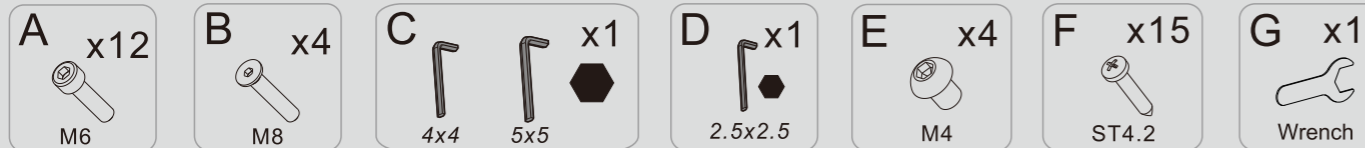

Part list

No.	Part	Qty	No.	Part	Qty	No.	Part	Qty
①	Pedestal	2	②	Column	1	③	Column	1
④	Supporting beam	1	⑤	Transmission rod	1	⑥	Supporting plate	2
⑦	Adapter	1	⑧	Baffle	2	⑨	Power cable	1
⑩	Cable tie	4	⑪	Adaptor holder	1			

Installation instruction

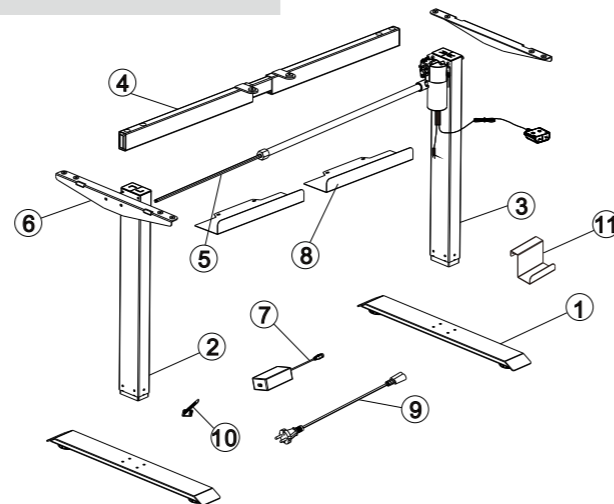

STEP1

Install Pedestal(1)

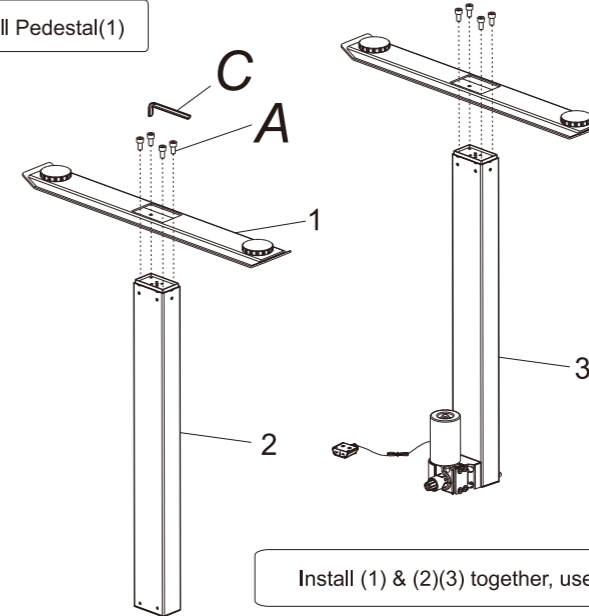

Install (1) & (2)(3) together, use 5*5 wrench(C) to tighten the screws(A).

STEP2

Install Supporting beam(4)

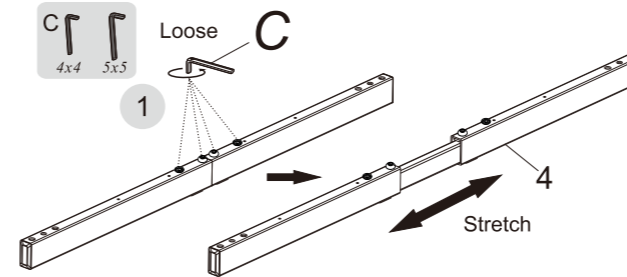

Loose screws on (4) with wrench 4x4(C), then stretch supporting beam

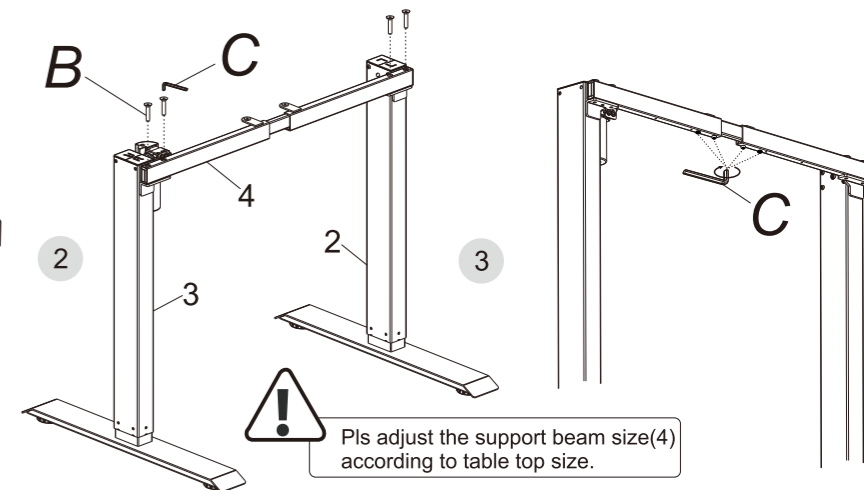

Install supporting beam on the column (2)(3), tighten screw (B) with wrench 5x5 (C)

Tighten screws on supporting beam with wrench 4x4(C)



Pls adjust the support beam size(4) according to table top size.

STEP3

Install transmission rod(5)

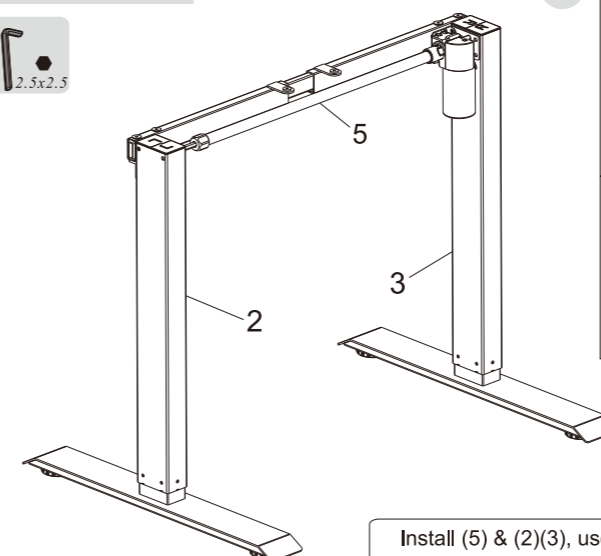

Install (5) & (2)(3), use 2.5*2.5 wrench(D) to tighten(G).



Rotation angle does not exceed one third of the circle

STEP4

Install supporting plate(6)

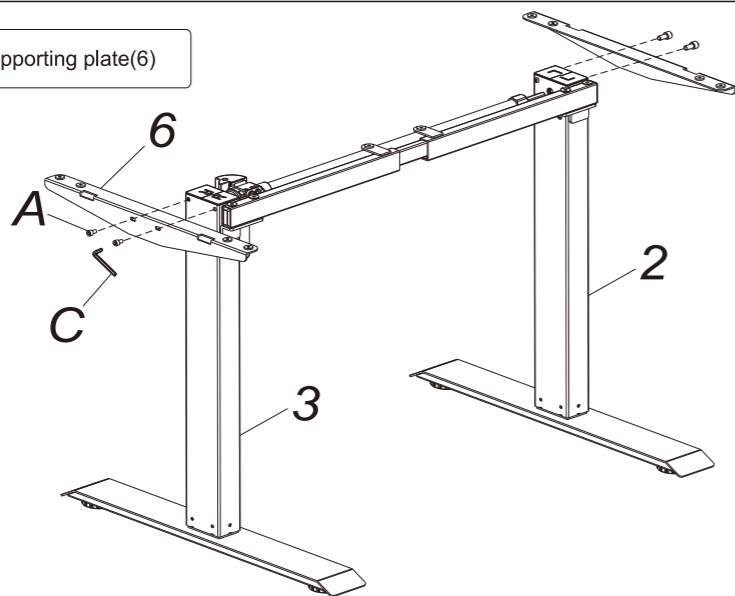
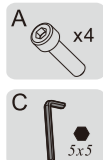

Install(6)&(2)(3), use 5*5 wrench(C) to tighten the screws(A).

STEP7

Connect all cables to the adaptor (7)

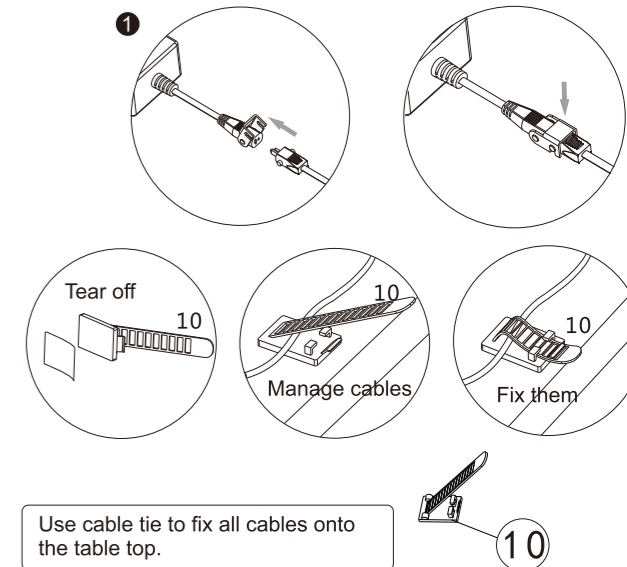
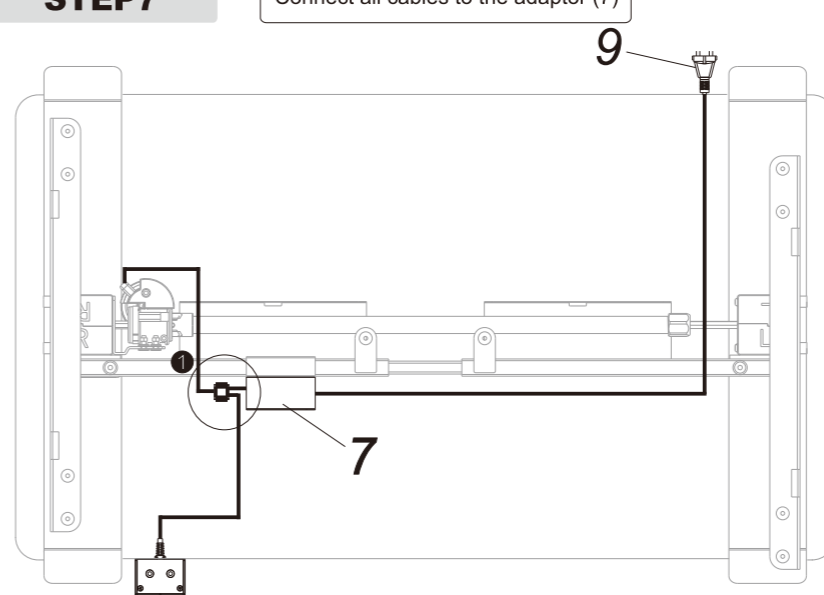

Use cable tie to fix all cables onto the table top.

STEP5

Install the power adaptor and desktop

Connect the table top with screws (F) and then lock it with pistol drill.

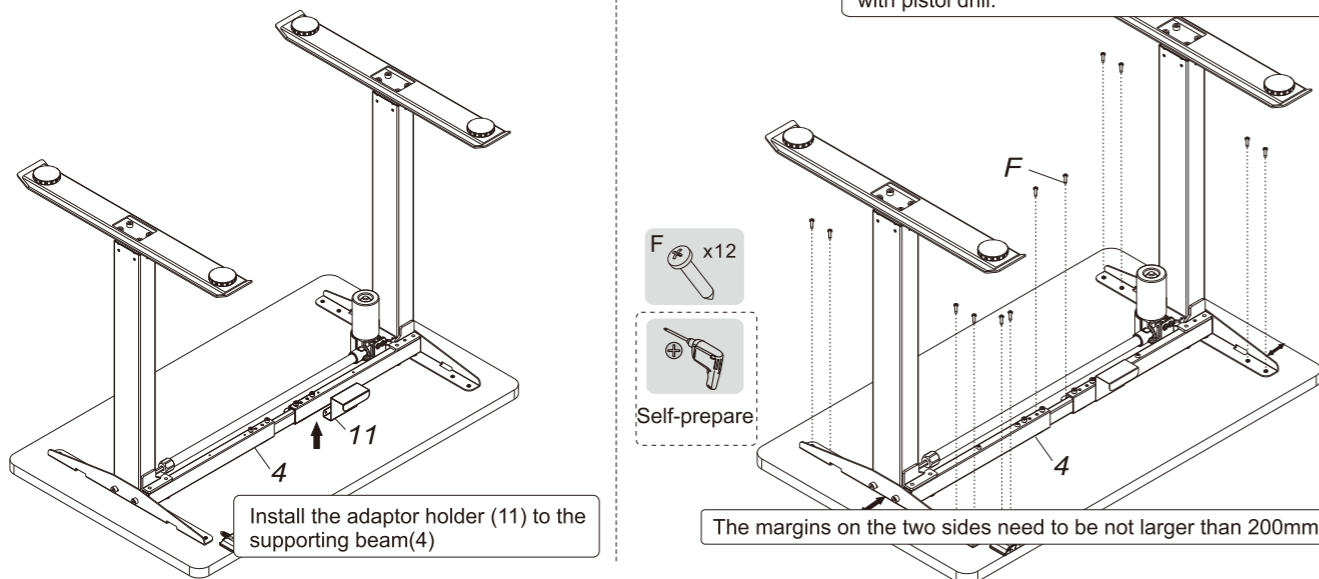

Install the adaptor holder (11) to the supporting beam(4)

The margins on the two sides need to be not larger than 200mm.

How to use handswitch

- “▲” Adjust the desk upwards
- “▼” Adjust the desk downwards

Instruction

Press the UP button or DOWN button to lift or lower the height of desk surface.

Common fault treatment

The following tips will help you detected and eliminate the common fault and error. If the fault you met is not listed below, please contact with your supplier. Only the manufacturer and professionals are capable for investigating and correcting those fault and error.

Fault phenomenon	Method
No response while long pressing down arrow after connected with a power supply	1.Check if all the cables be connected well 2.Contact your supplier or dealer
The desktop could not be lifted	1.Check if overloaded, max loading: 70kg 2.Contact your supplier or dealer
Overwork (Duty cycle:Max 2min on/30min OFF)	1.Restart it after suspend for 30mins for the working time is too long 2.Contact your supplier or dealer

Button

DOWN button

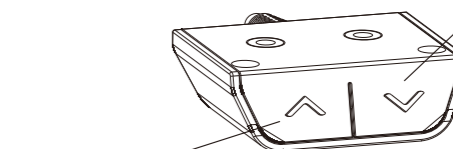

UP button



Attention

1. Power supply: AC100V-240V,50/60HZ
2. Service Environment: 0-40°C
3. Unplug the power plug before cleaning, wipe the dust on surface with slight wet dishcloth when cleaning, be careful not to let the drops into the internal parts, not loose the connector.
4. The electric box contains electronic components, metals, plastics, wires etc., so dispose of it in accordance with each country's environmental legislation, not the general household waste.
5. Check carefully to ensure correct and complete assembly before using.
6. Be familiar with all functions and program settings of the product before first use.
7. Children are forbidden to play on the product because of unforeseen action when playing, so any dangerous consequences caused by this improper action will not be on
8. Slight noise caused by the V-ribbed belt or brake system due to structure will not have any effect on the use of the equipment.
9. Corrosive or abrasive materials are forbidden to clean the equipment. Must ensure that the cleaner used will not pollute the environment.
10. Please make sure there is no hazard sources in your operating environment. e.g., do not litter the tools around. Always be careful to treat the packaging materials in order to avoid any possible danger, e.g. plastic bag may lead to choking hazard to children.
- 11.Keep the original package of the equipment if necessary in case of the future use in transportation.
- 12.The following tips will help you detected and eliminate the common fault and error. If the fault you met is not listed below, please contact with your supplier. Only the manufacturer and professionals are capable for investigating and correcting those fault and error.

STEP6

Install baffle and power adaptor

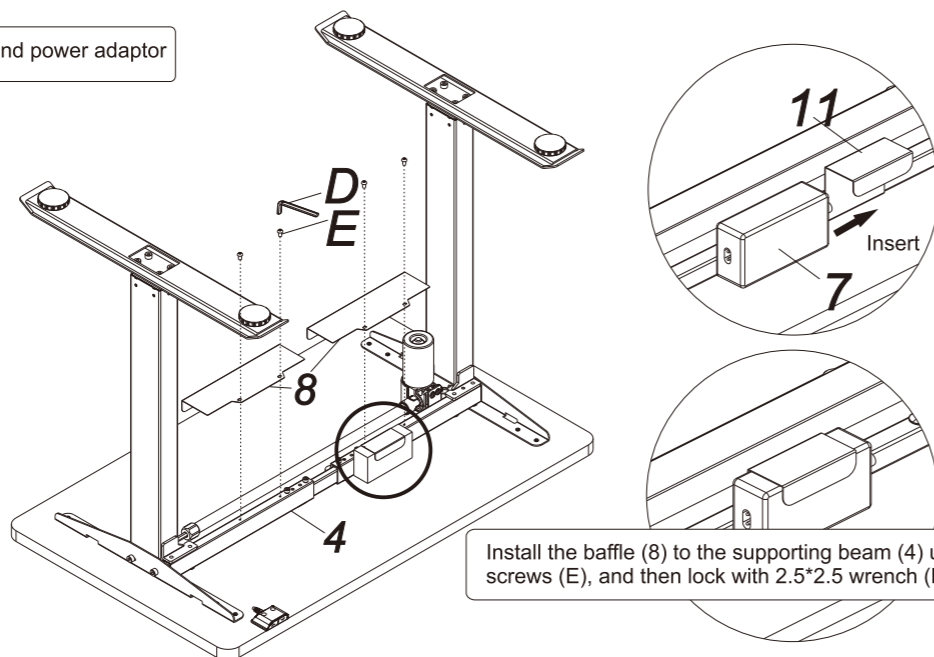
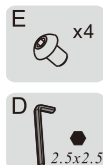

Install the baffle (8) to the supporting beam (4) using screws (E), and then lock with 2.5*2.5 wrench (D).

Waste disposal



This marking indicates that this product should not be disposed with other household wastes. To prevent possible harm to the environment or human health from uncontrolled waste disposal, recycle it responsibly to promote the sustainable reuse of material resources. To return your used device, please use the return and collection systems or contact the retailer where the product was purchased. They can take this product for environmental safe recycling.