

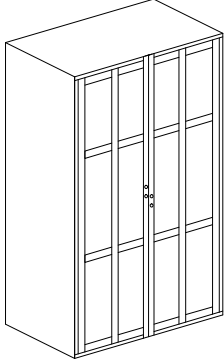

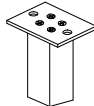
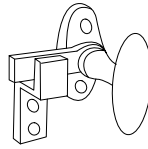

# ASSEMBLY INSTRUCTIONS

ITEM NO. - 1681911-01-0

## PARTS LIST

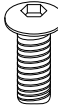
| P1  | x1 | P2  | x4 | P3  | x1 | A   | x8        | B  | x8        | C   | x8    | D   | x1 | E   | x4    |
|---|----|---|----|---|----|---|-----------|--|-----------|---|-------|---|----|---|-------|
|  |    |  |    |  |    |  | M8xO.D.20 |  | M8xO.D.10 |  | M8x20 |  | #5 |  | 20 MM |

### STEP - 1

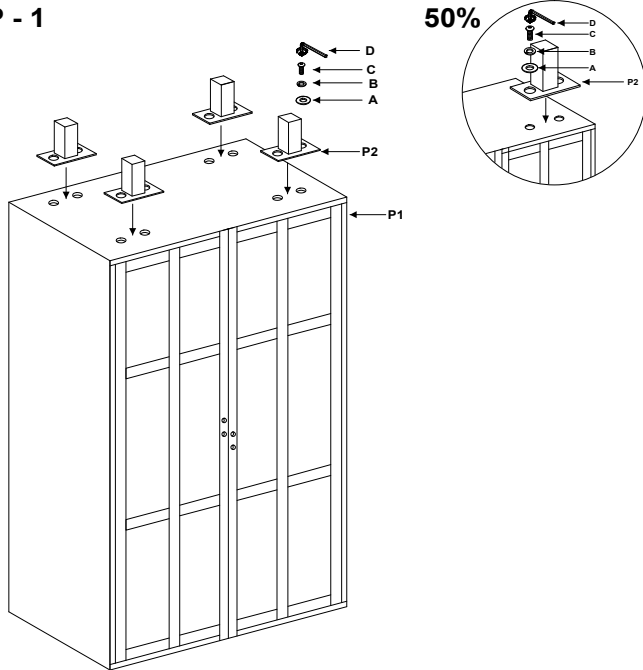

### STEP - 2

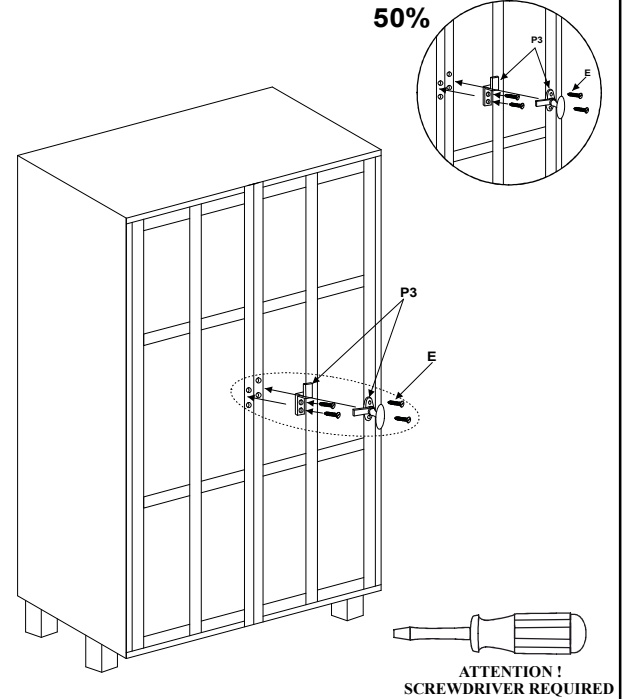

### READY TO USE

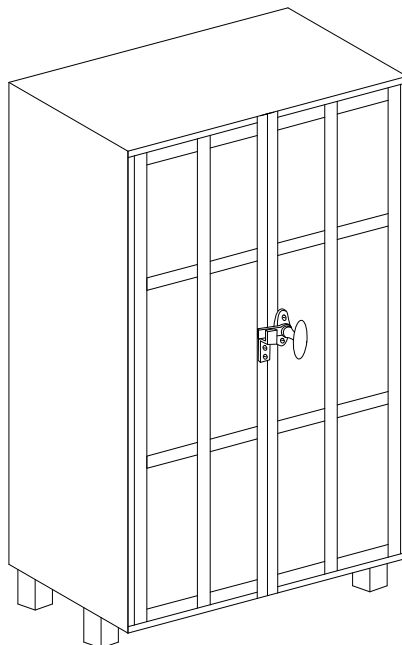

# ANTI-TIP ASSEMBLY INSTRUCTIONS

ITEM NO. - 1681911-01-0

1

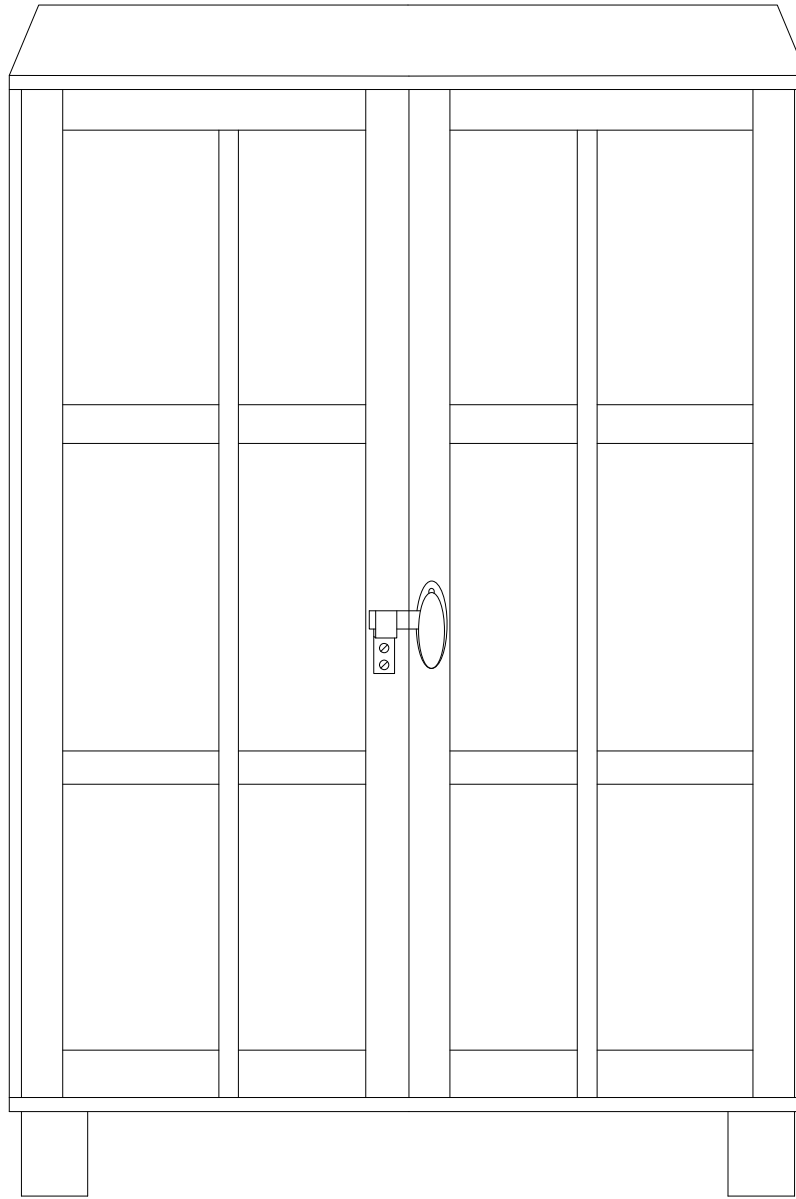

2

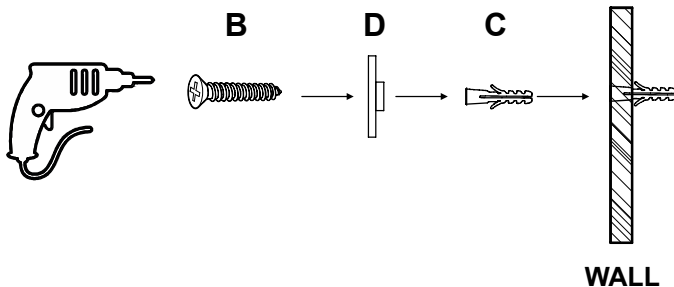
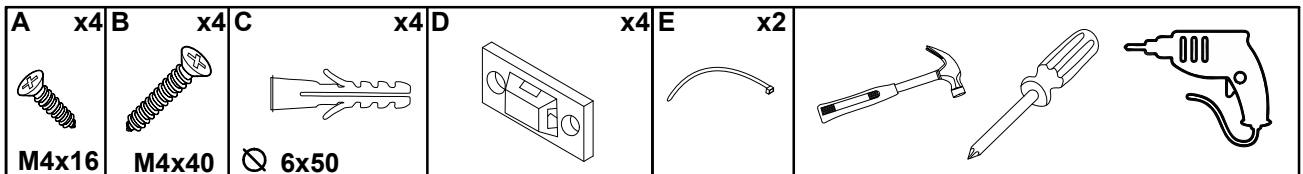

**3**

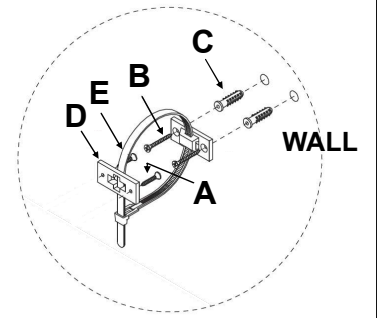
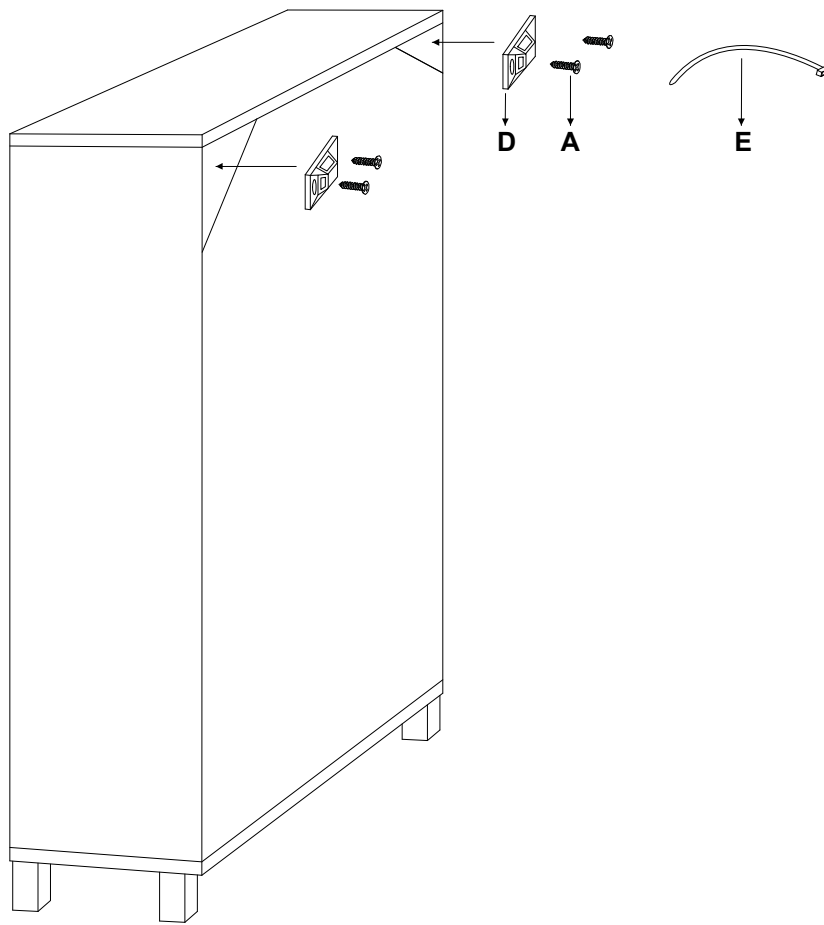

**4**

