

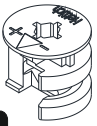

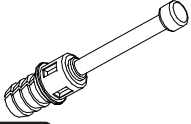

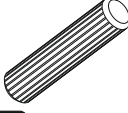

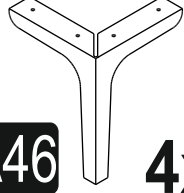

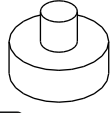

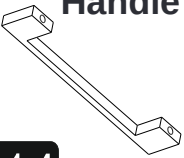
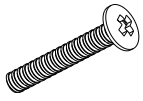
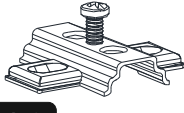
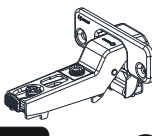
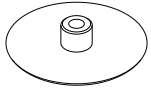
NO	Width	Length		Piece
1	400	475	18	1
2	400	475	18	1
3	1800	450	18	1
4	1800	475	18	1
5	362	450	18	1
6	362	440	18	3
7	1795	377	18	1
8	1833	397	4	1

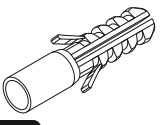
## ACCESSORY LIST

 <b>A01</b> 12x	 <b>A02</b> 12x	 <b>A03</b> 12x	 <b>A46</b> 4x	 <b>A47</b> 4x	 <b>A10</b> 38x
 <b>A14</b> 1x	 <b>A15</b> 2x	 <b>A13</b> 3x	 <b>A11</b> 3x	 <b>A04</b> 12x	 <b>A28</b> 22x
 <b>A08</b> 1x	 <b>A09</b> 1x		 <b>A21</b> 2x	 <b>A22</b> 1x	 <b>A23</b> 12x

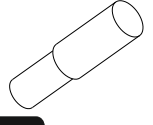
 <b>A07</b> 1x
--

 <b>A06</b> 1x
---

Sayın Müşterimiz,

Satınalmış olduğunuz bu ürün sizlere ulaşmadan önce tarafımızdan tüm testlere ve kontrollere tabii tutulmuştur. Bu durumda bile taşıma sırasında bazı parçaların zarar görmesi mümkündür. Böyle bir durum ile karşılaşırsanız ürünün tamamını geri göndermeyiniz. Sadece zarar gören parçayı isteyiniz. Gerekli parçayı isterken ise servis kartına bakarak tam olarak parçayı tanımlayınız. Eksik olan parça en hızlı şekilde tarafınıza gönderilecektir.

Montaja başlamadan önce kutulardan çıkan tüm parça ve aksesuarları listelere göre kontrol ediniz. Parça ve aksesuarların tam ve sağlam olduğunu tespit ettikten sonra montaja başlayınız. Montaja başlamadan önce her parçayı nemli bir bez ile temizleyiniz. Eğer birden fazla ürün aldıysanız herhangi bir karışıklığa sebep vermeme için tek bir ürün montajını yaptıktan sonra diğer ürüne geçiniz. Ürünleri hiç bir zaman sürterek taşımayınız. Ürünü kaldırarak ve sökerek en az iki kişi ile taşıyınız. Uzun mesafeli taşımalarda ürünü mutlaka paket ile taşıyınız.

Almış olduğunuz mobilyalarınızın yüzeylerinin temizlenmesi çok kolaydır. Nemli ve sabunlu bir bez ile veya diğer ev temizleyicileriyle silmek yeterlidir. Mobilyalar aşırı sıcak, soğuk ve nemden etkilendiklerinden, mobilyanızı bu faktörlere direkt olarak temas ettirmeyiniz. Mobilyanızı amacı dışında kullanmayınız.

# ASSEMBLY INSTRUCTIONS

# MODULE P - R - S

Q2

1. PROCEDURE

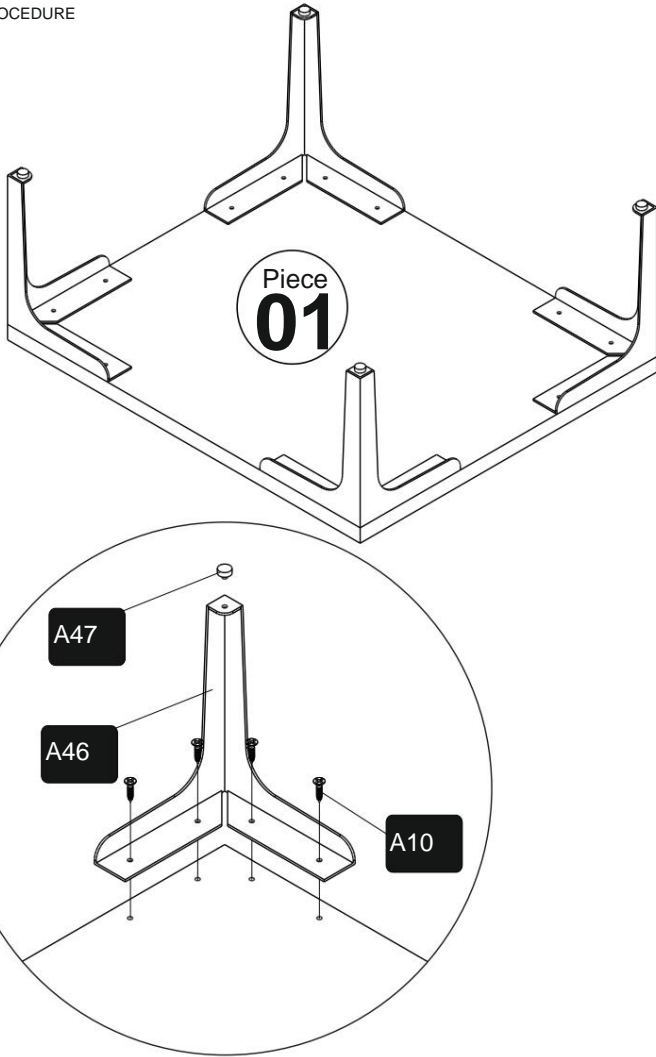

2. PROCEDURE

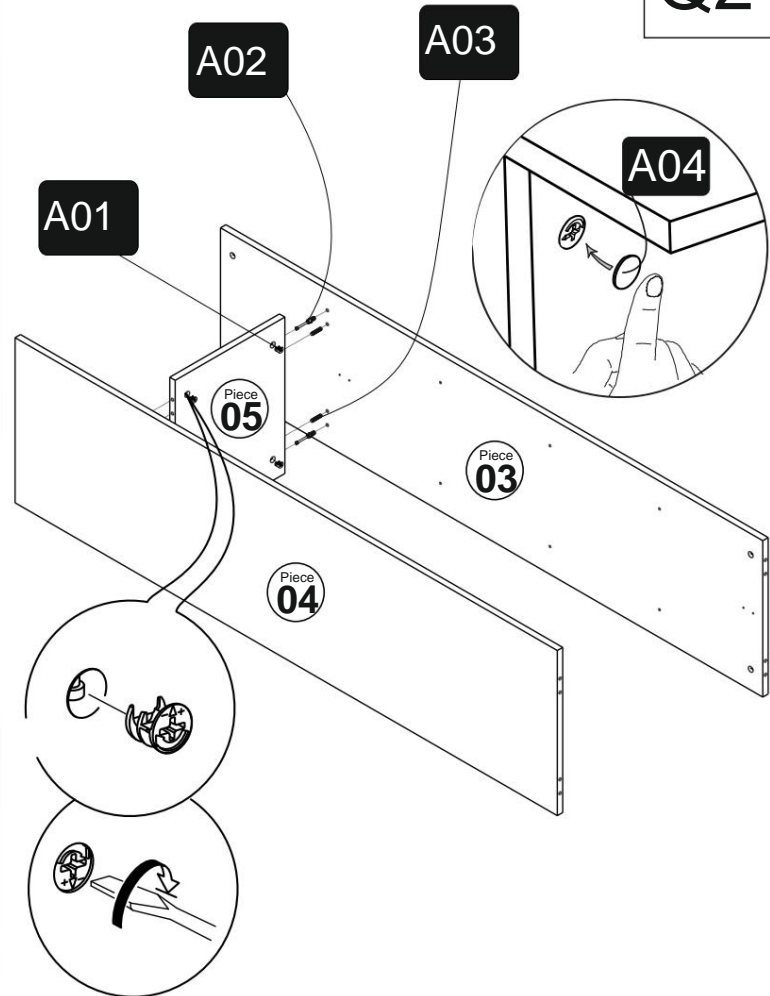

3. PROCEDURE

FOR THE OPENING DOOR TO THE LEFT

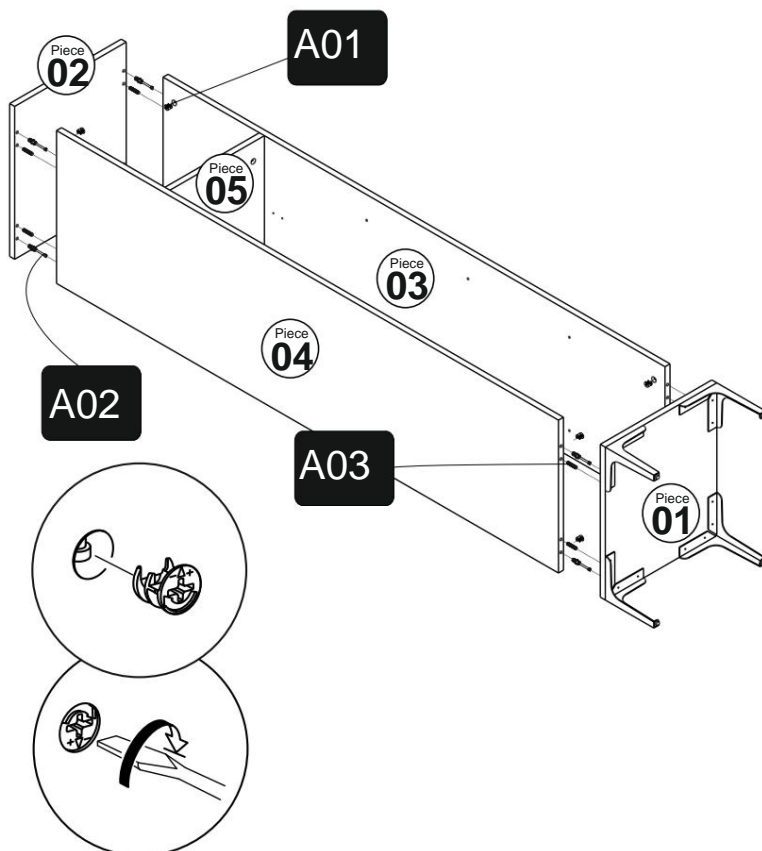

4. PROCEDURE

FOR THE DOOR TO OPEN TO THE RIGHT

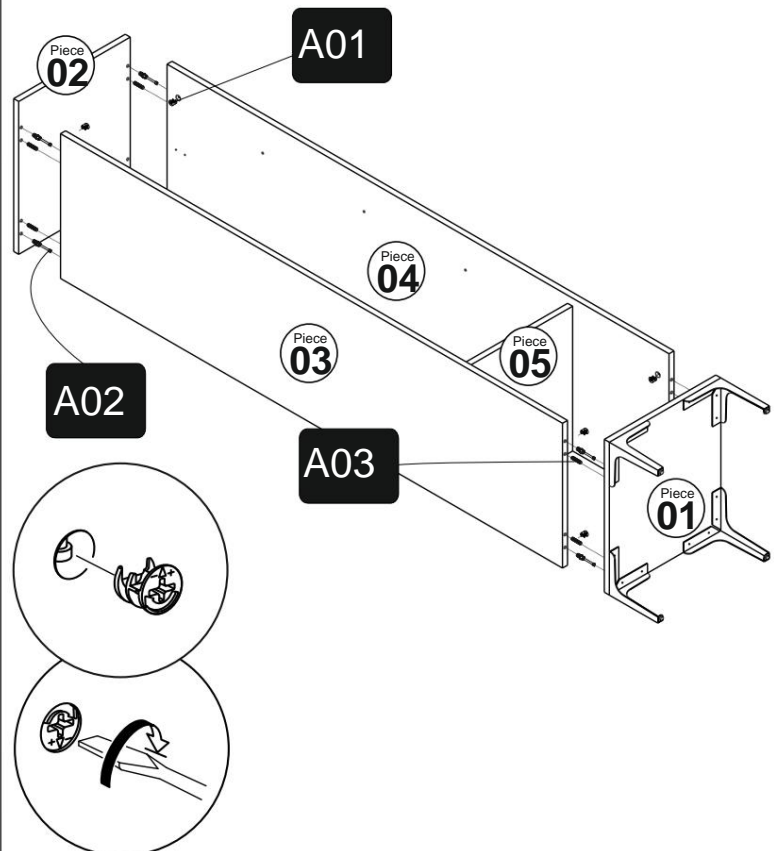

5. PROCEDURE

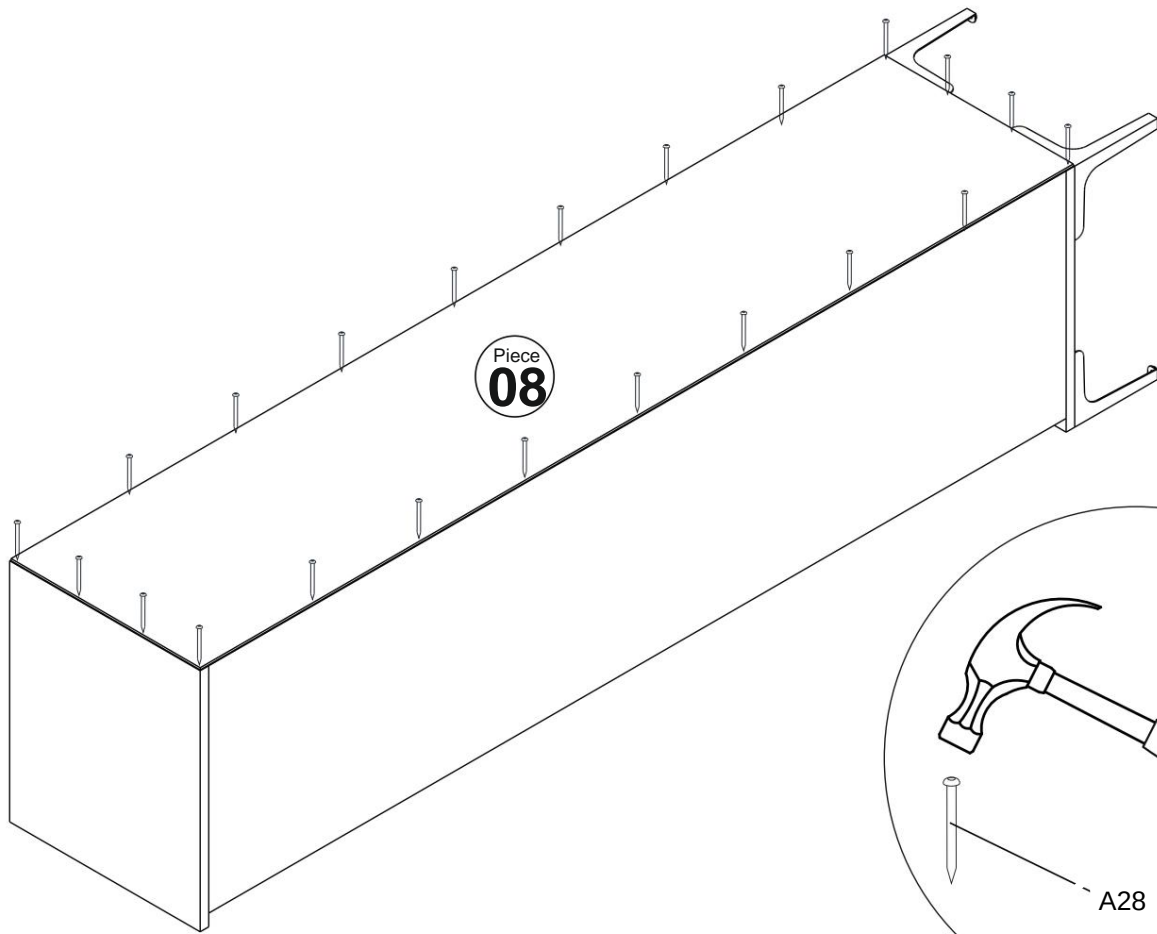

6. PROCEDURE

FOR THE OPENING DOOR TO THE LEFT

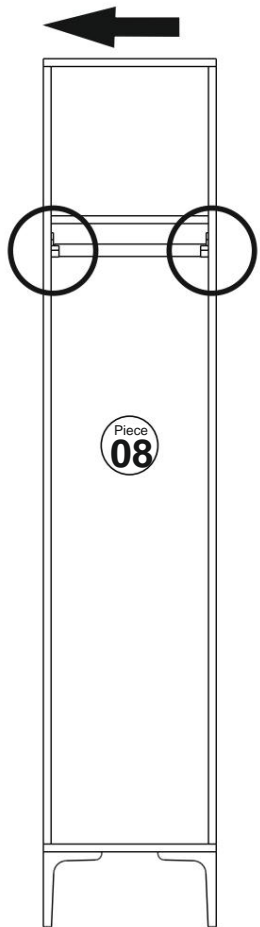

FOR THE OPENING DOOR TO THE LEFT

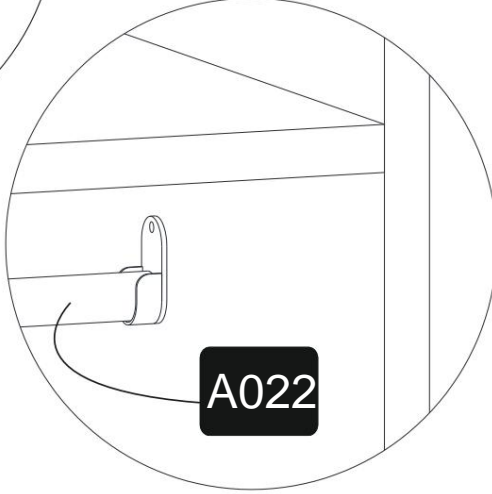
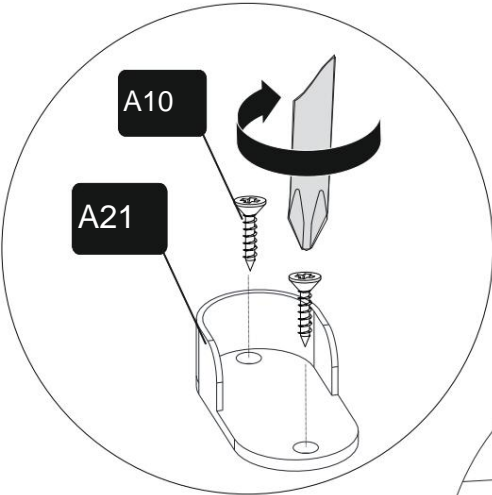
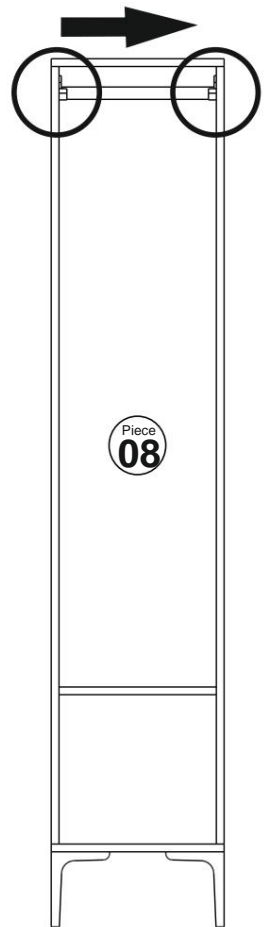

7. PROCESS

FOR USE WITH SHELVES

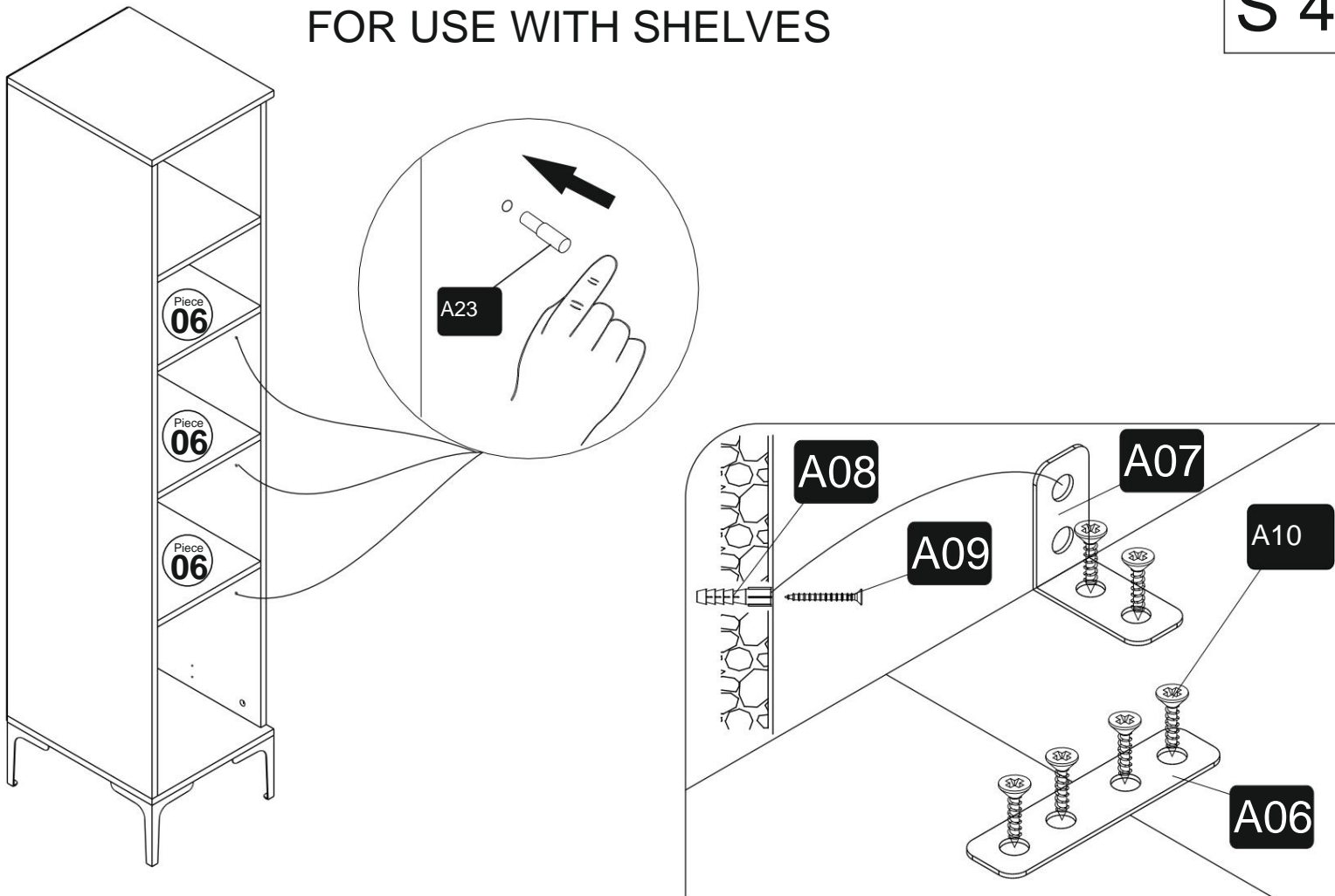

8. PROCESS

