

# Adjustable bed

## ASSEMBLY / MONTERING

---

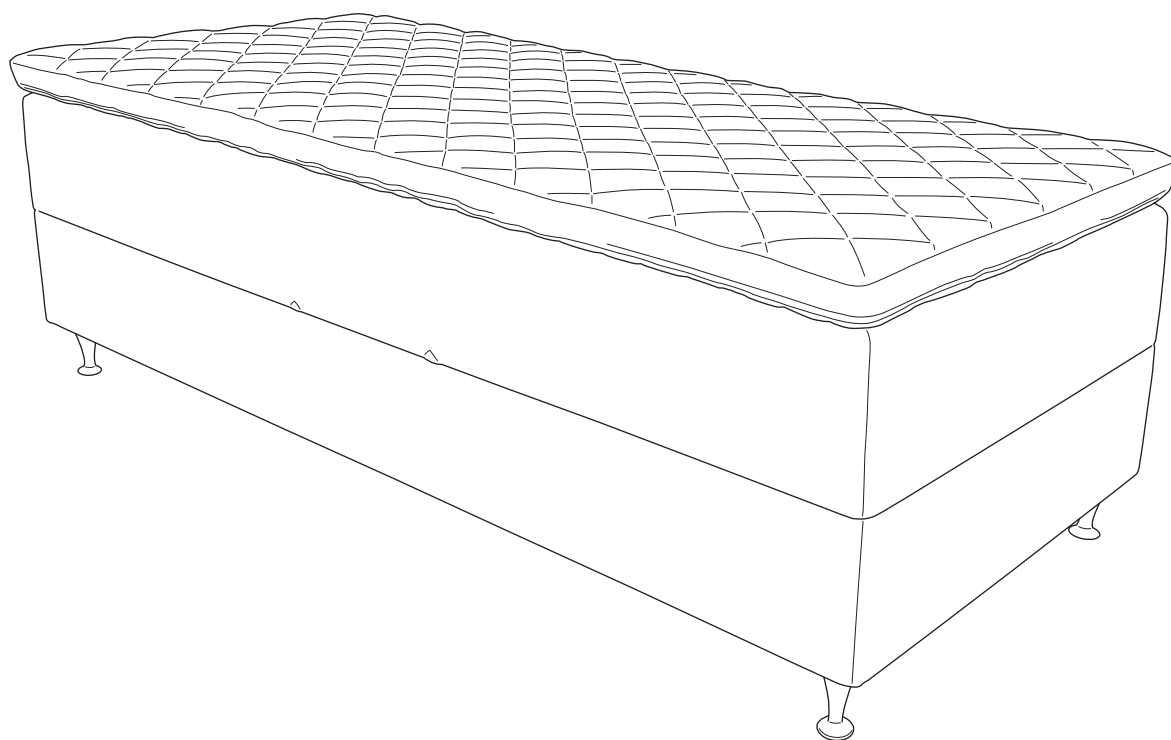

## YOU NEED / DU BEHÖVER

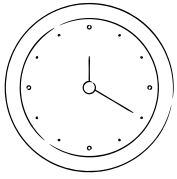

ca 45 min

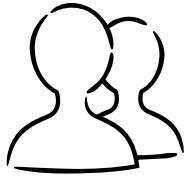

2 persons / 2 personer

## PARTS / DELAR

	Qty / Antal
A	4
B	4
C	1

A

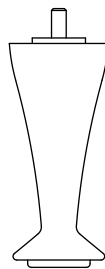

B

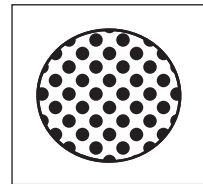

C

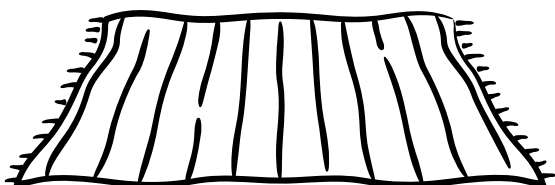
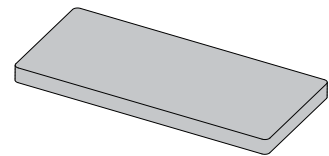

Place your product on a soft surface when assembling.

Lägg dina produkter på ett mjukt underlag när du monterar.

## **ASSEMBLY / MONTERING**

Follow the instruction step by step.

Följ instruktionerna steg för steg.

1.

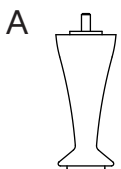
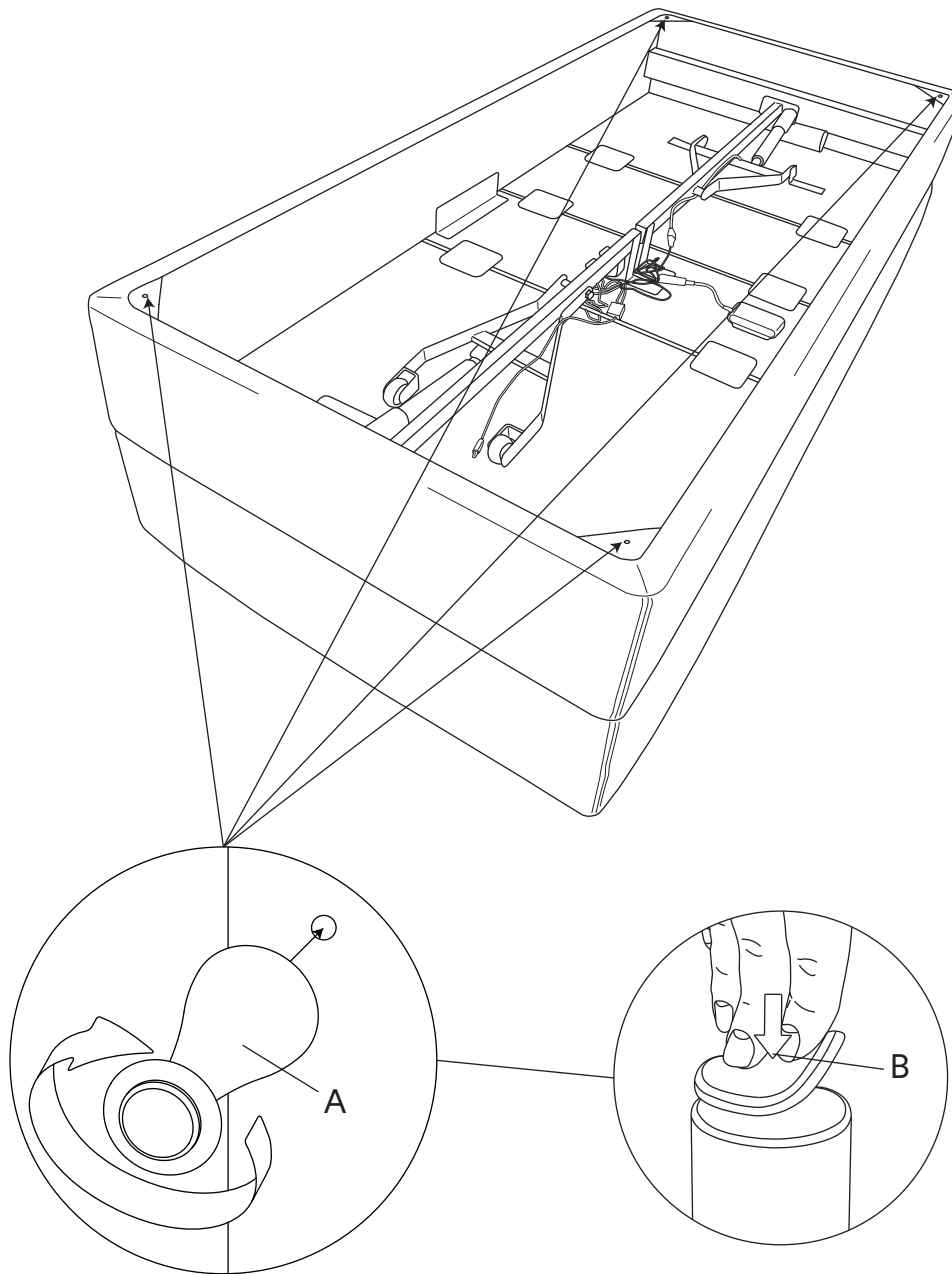

## **ASSEMBLY / MONTERING**

Follow the instruction step by step.

Följ instruktionerna steg för steg.

2.

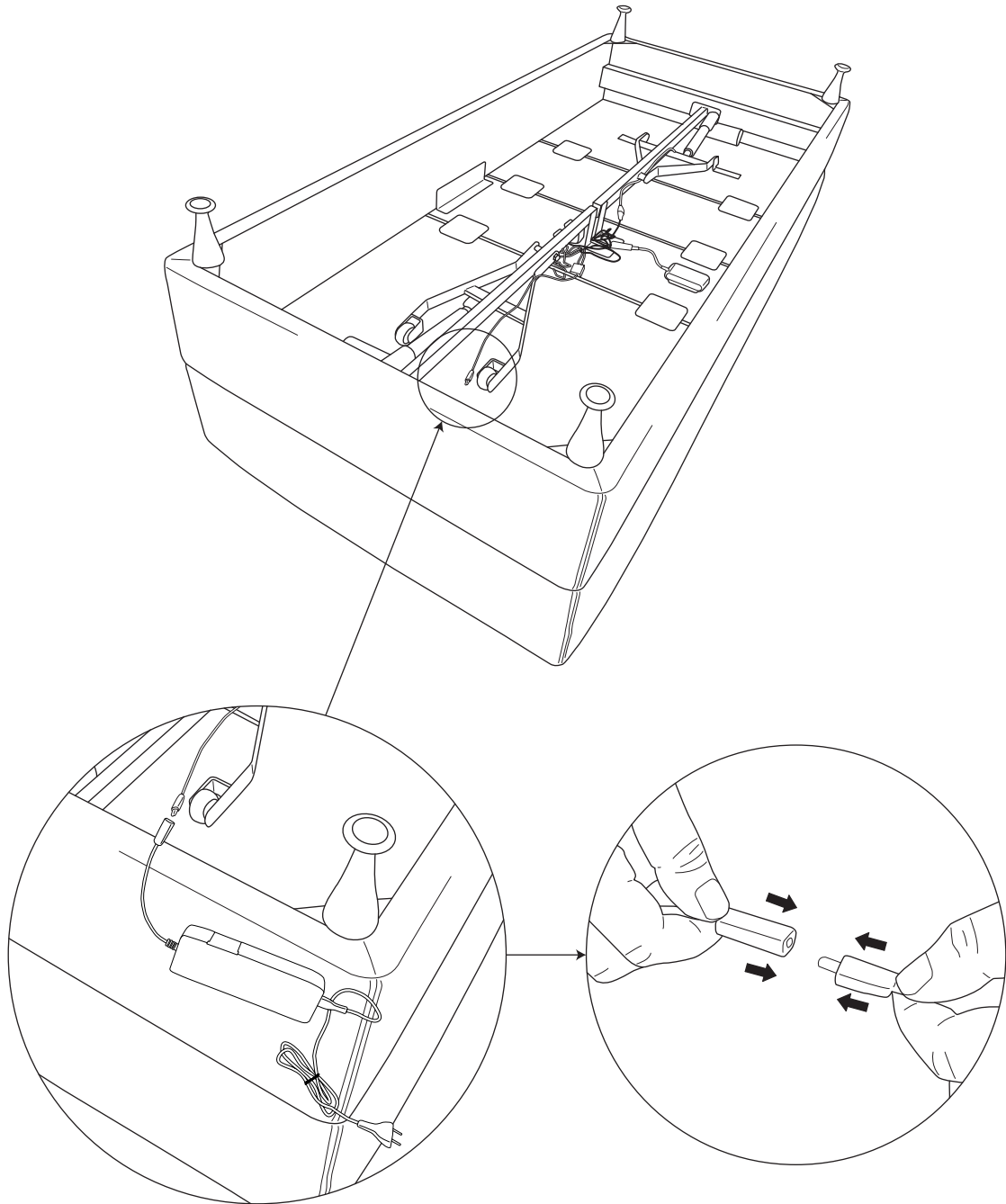

## **ASSEMBLY / MONTERING**

Follow the instruction step by step.

Följ instruktionerna steg för steg.

3.

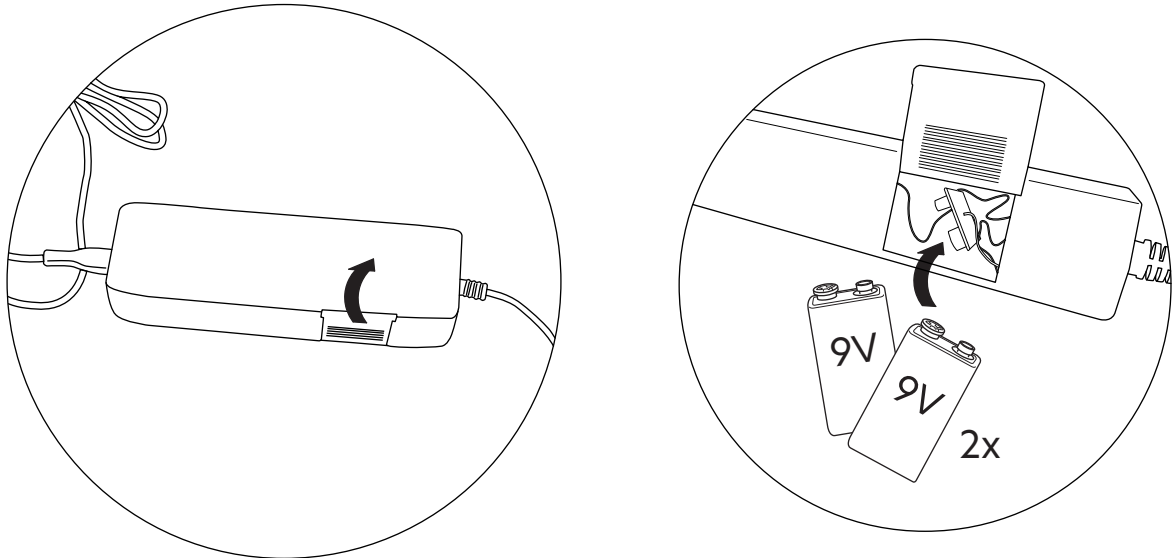

1. Open the cover of the battery compartment on the power block.

2. Insert two 9V batteries (not included) for emergency lowering. The batteries are not needed for daily use, as the bed has power.

4.

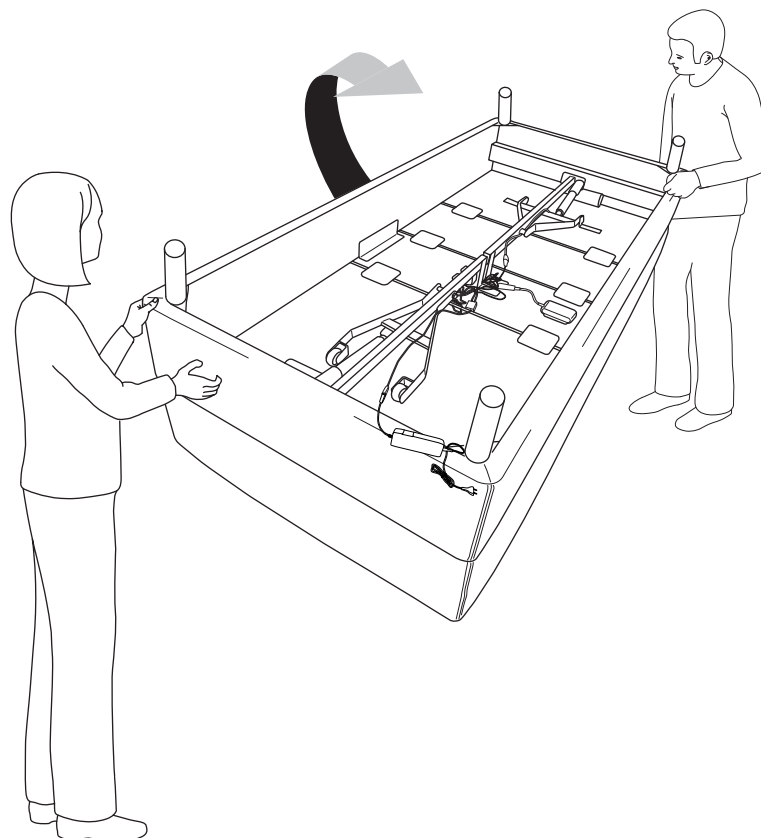

## ASSEMBLY / MONTERING

Follow the instruction step by step.

Följ instruktionerna steg för steg.

5.

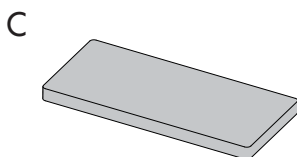
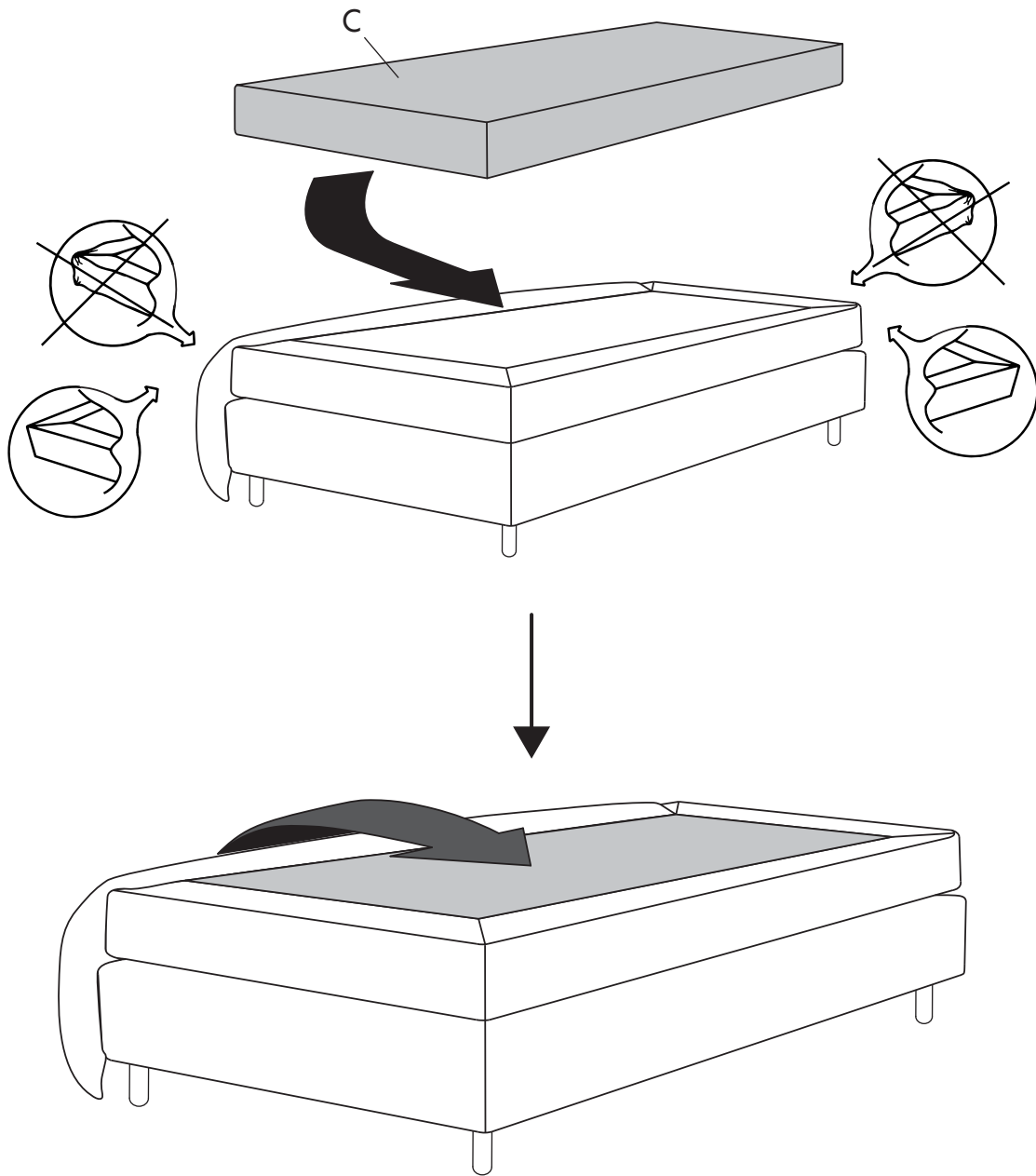

## **ASSEMBLY / MONTERING**

Follow the instruction step by step.

Följ instruktionerna steg för steg.

6.

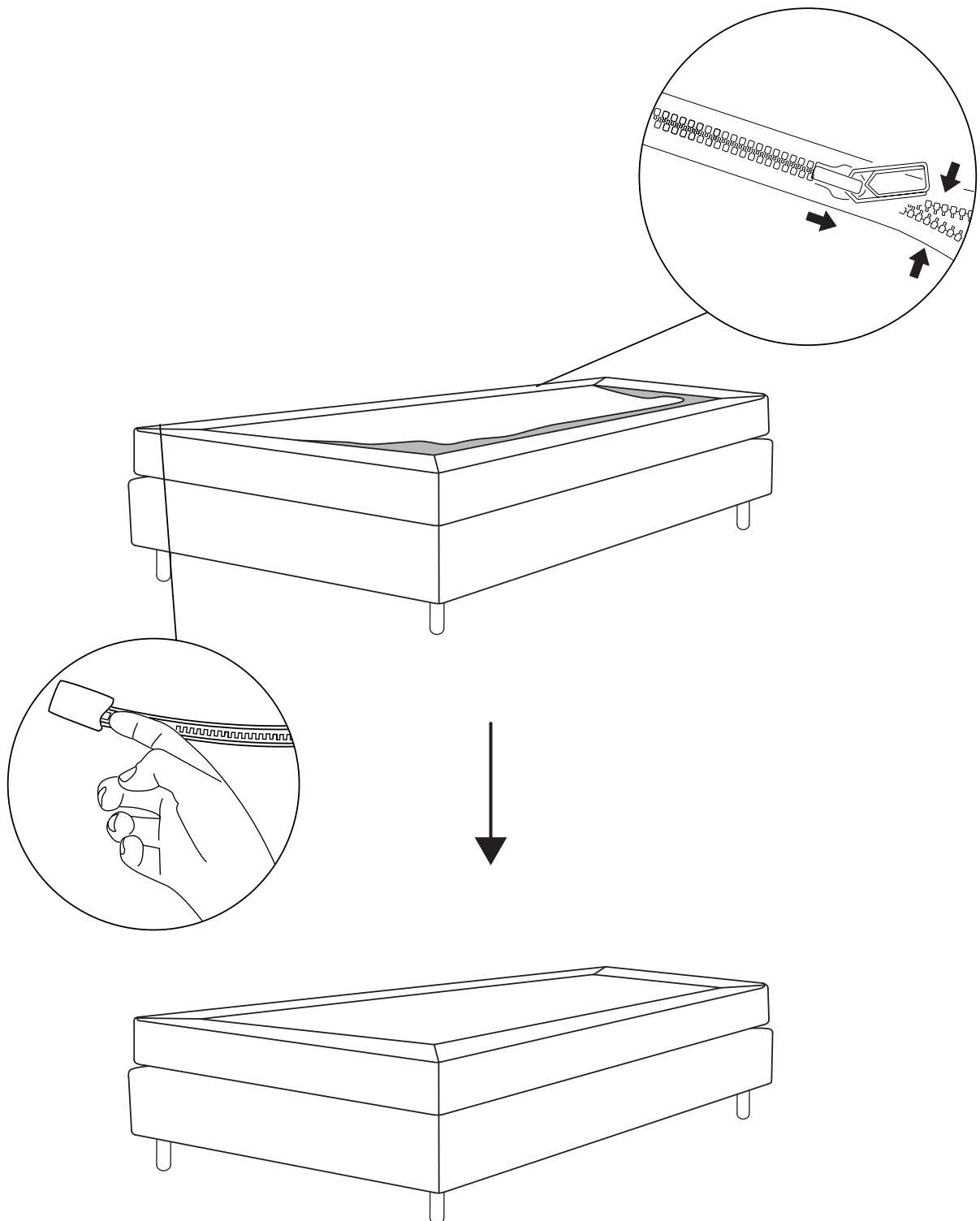

## ASSEMBLY / MONTERING

Follow the instruction step by step.

Följ instruktionerna steg för steg.

7.

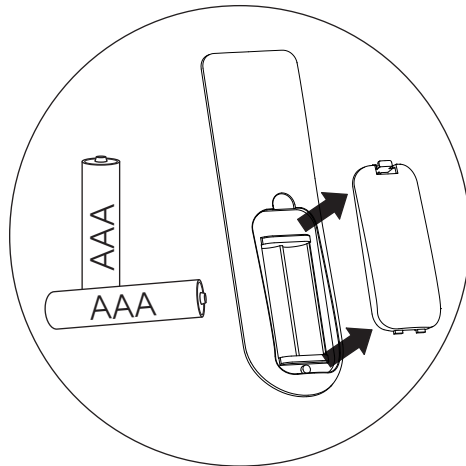

1. Open the lid on the remote control and insert 2 AAA batteries. Make sure to connect to correct poles (+/-) on the batteries.

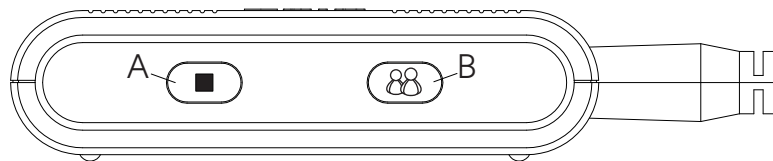

2. Press the connection button (B) 2x on the OKIMAT until the LED lights up. You now have 60 seconds to connect.

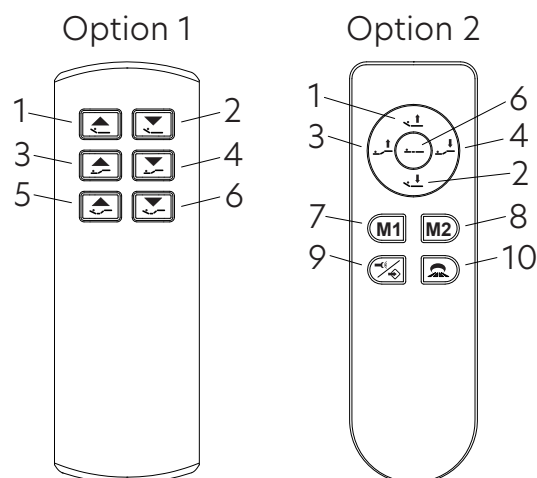

3. Press buttons (1) and (2) simultaneously on the remote control until the LED light starts flashing. When the LED receiver flashes, the connection is complete. Note: The distance between the receiver and the remote control should not be more than two meters during the connection process.



## ASSEMBLY / MONTERING

Follow the instruction step by step.

Följ instruktionerna steg för steg.

### 8. FUNCTIONS OF THE BUTTONS

A  Emergency lowering

B  Connection

1  Back part up

2  Back part down

3  Foot part up

4  Foot part down

5  Reset - both up

6  Reset - both down

7  Select saved positions

8 

When programming a new position, it will automatically write over the old one.

Press the "position memory" (7) or (8) until all moving parts have reached their programmed positions.

9  Save a position

Move to a desired position by pressing the movement buttons (1-6). Hold "save position" button  pressed until the light on the back of the remote control flashes twice. To save a position, press "position memory" buttons **M1** or **M2** within 2 seconds.

9  Light

Press and hold the button to turn on/off.

10  Floor lighting

Pressing the button turns floor lighting on/off.

## ASSEMBLY / MONTERING

Follow the instruction step by step.

Följ instruktionerna steg för steg.

### 9. MOVE YOUR BED WITH YOUR SMARTPHONE/TABLET

1. Download the "Furnimove" app via the App store or Google Play store for your smartphone/tablet.
2. Unplug the bed's power cord for 10 minutes and plug it back in. When the light on the motor under the bed flashes, it's ready to sync with the app.
3. Activate Bluetooth on your smartphone/tablet. Open the app and you will see a list of beds/motors that are in sync mode. Select the bed/motor in the list that you want to pair with and click it. Your smartphone/tablet is now synchronized with the app and ready to use. You will now see the operation page on the display. We recommend for you to activate the remote control first and then the smartphone/tablet to avoid having to turn off the power again.

ATTENTION! The app and the remote should only be used seperately, not simultaneously.

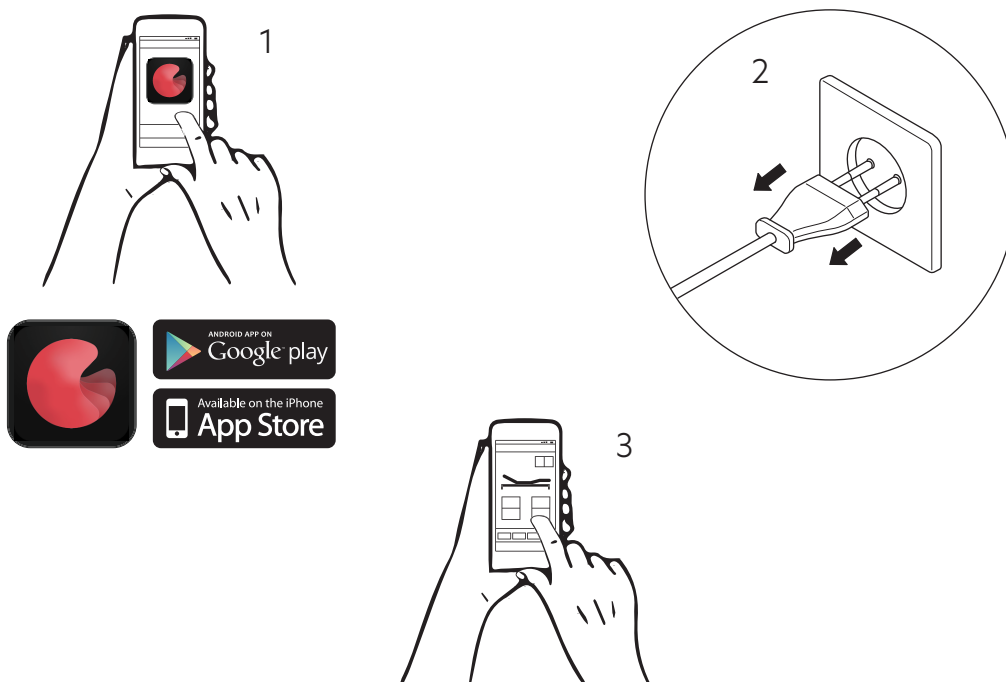

## DISASSEMBLY / DEMONTERING

Follow the instruction step by step.

Följ instruktionerna steg för steg.

1.

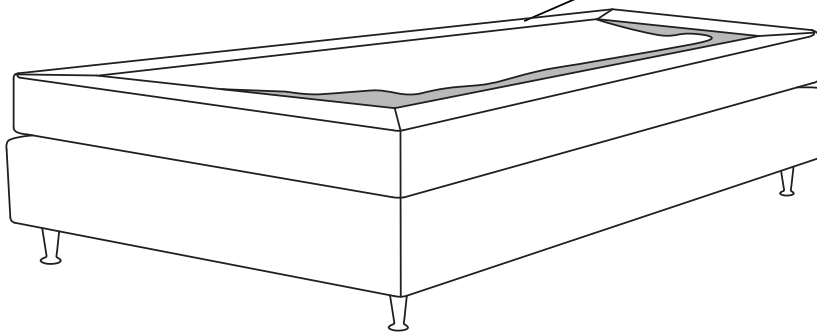
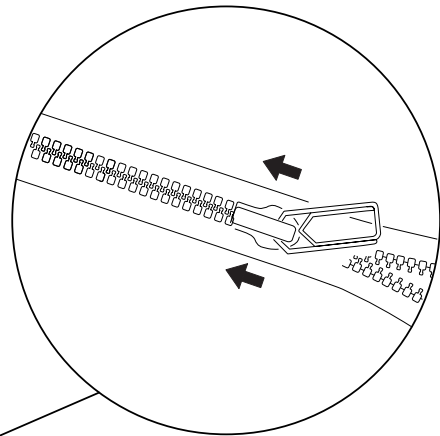
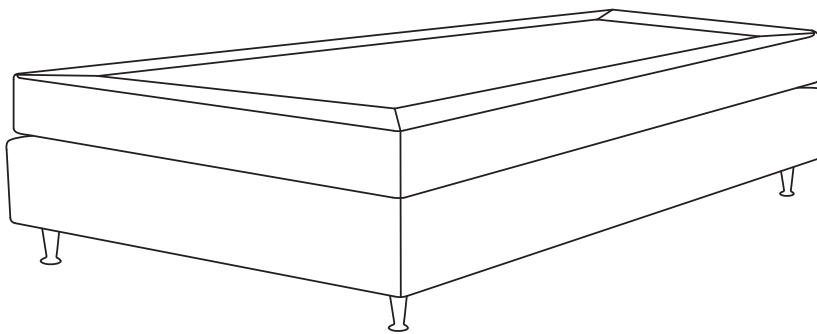

## DISASSEMBLY / DEMONTERING

Follow the instruction step by step.

Följ instruktionerna steg för steg.

2.

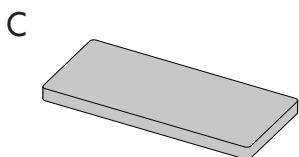
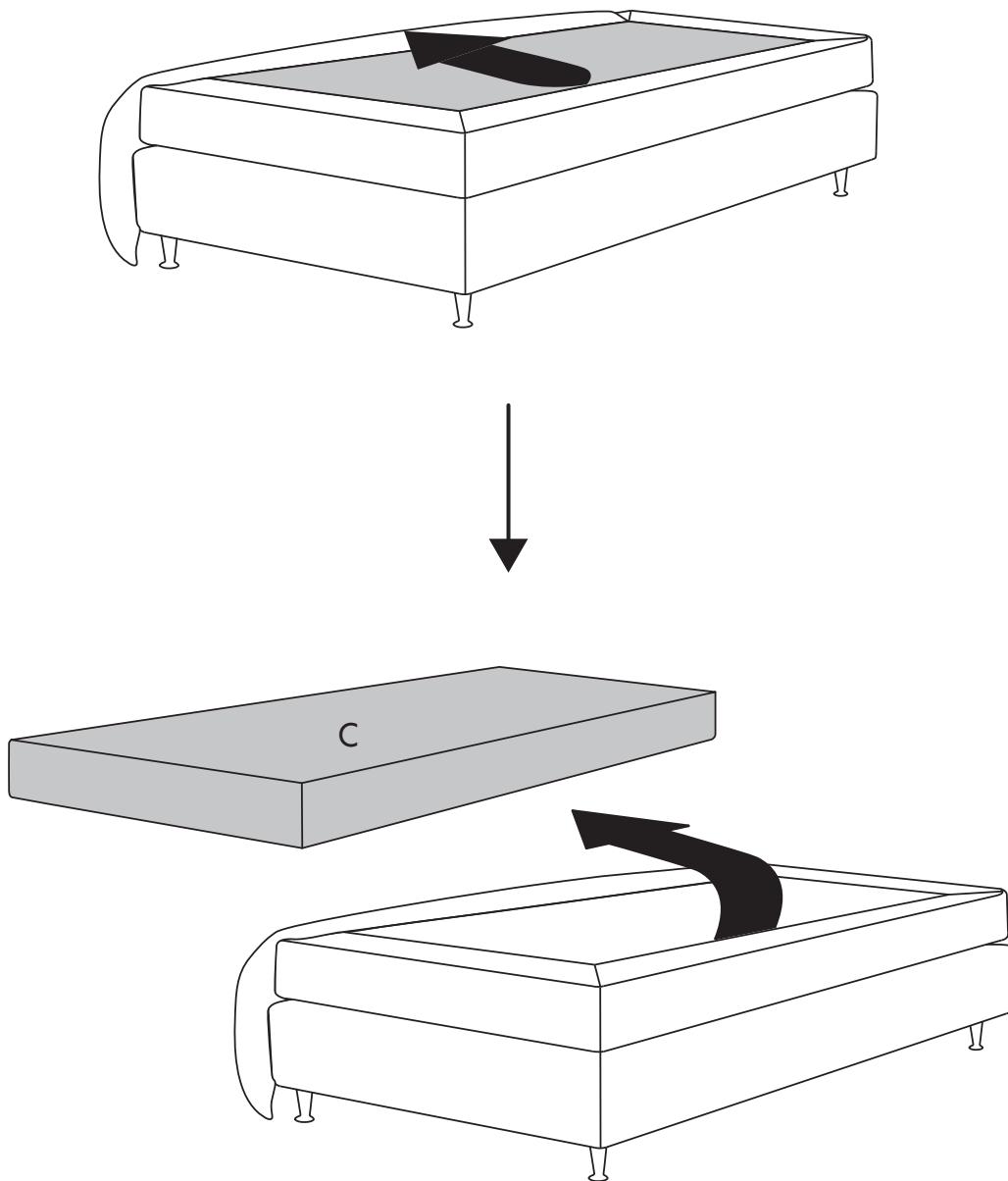

## **DISASSEMBLY / DEMONTERING**

Follow the instruction step by step.

Följ instruktionerna steg för steg.

3.

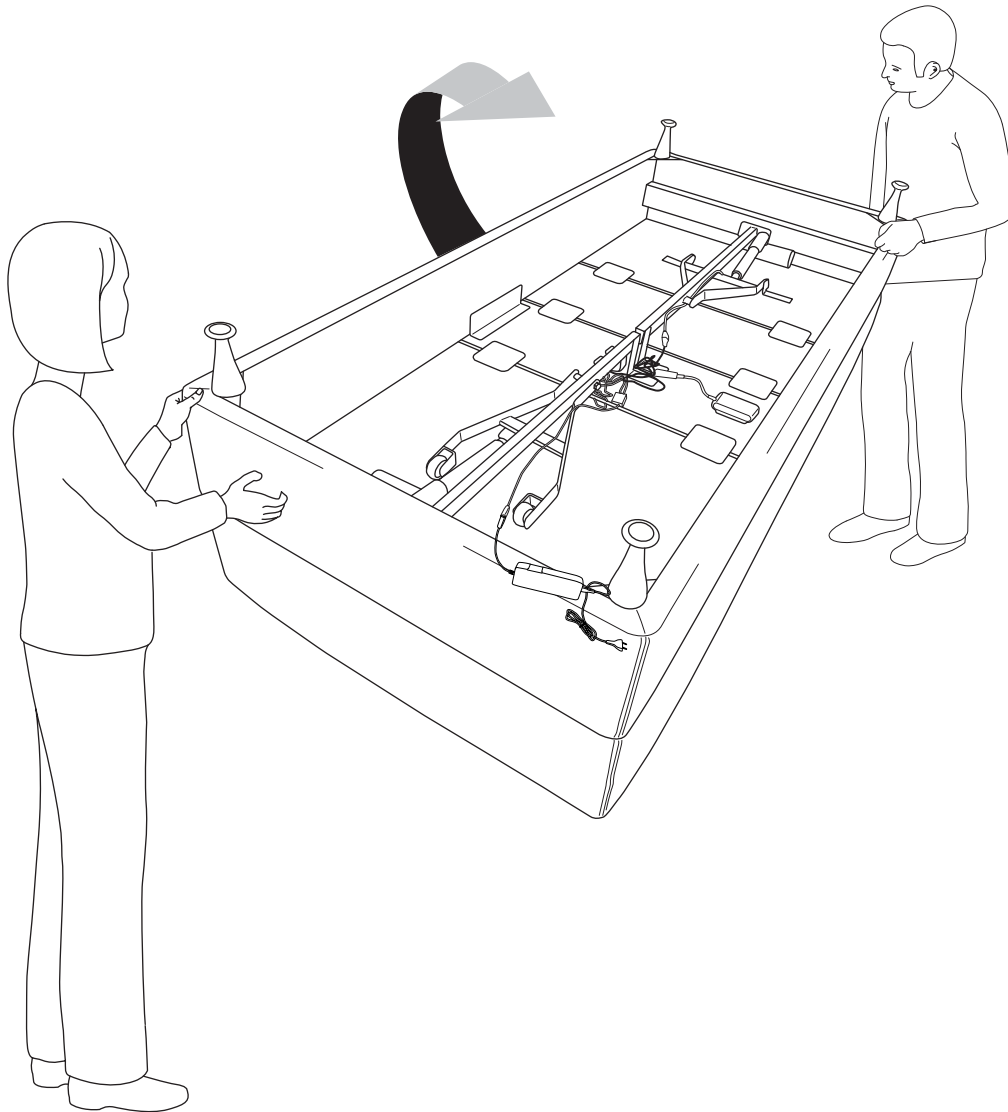

## **DISASSEMBLY / DEMONTERING**

Follow the instruction step by step.

Följ instruktionerna steg för steg.

4.

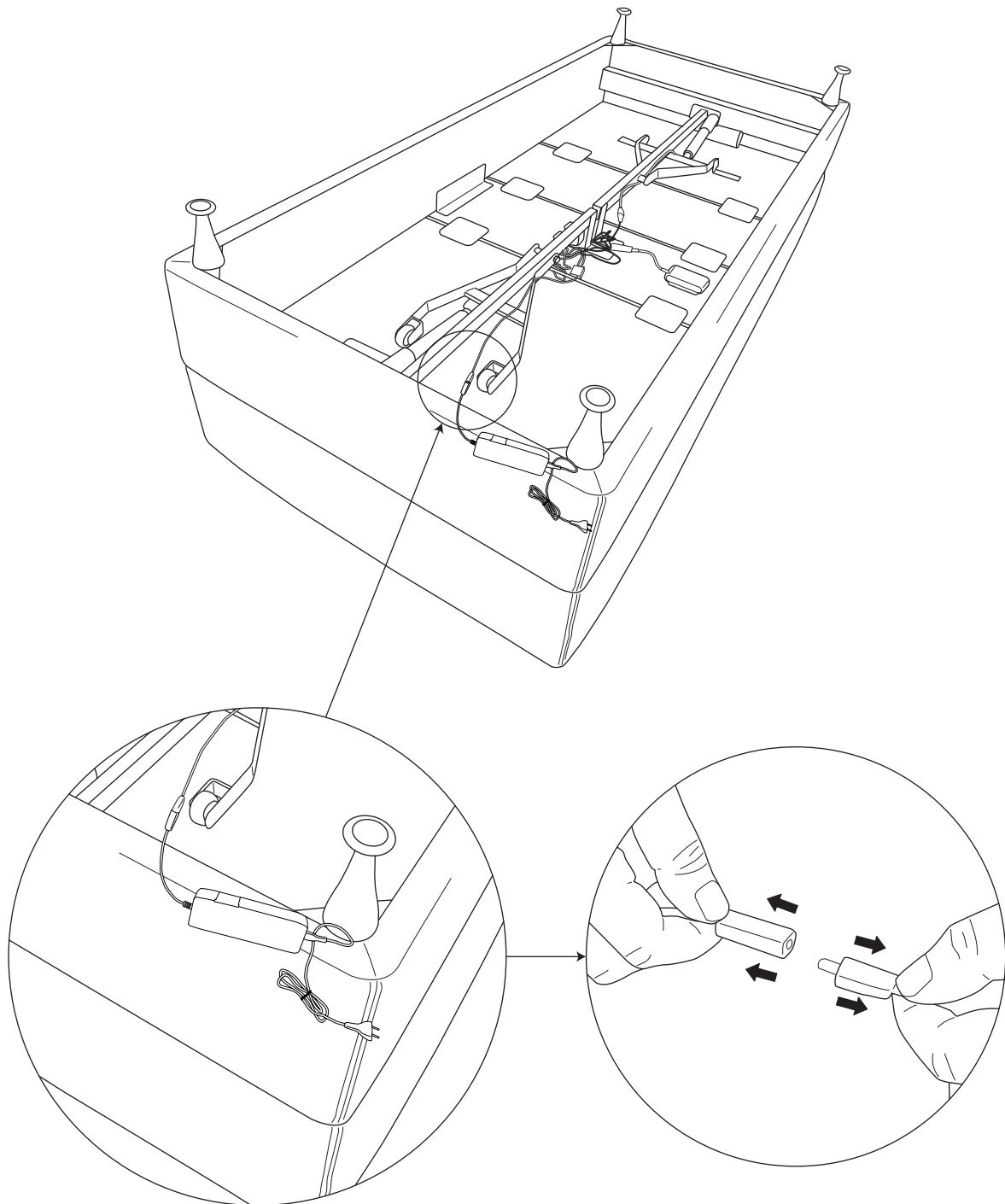

## **DISASSEMBLY / DEMONTERING**

Follow the instruction step by step.

Följ instruktionerna steg för steg.

5.

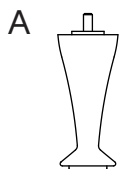
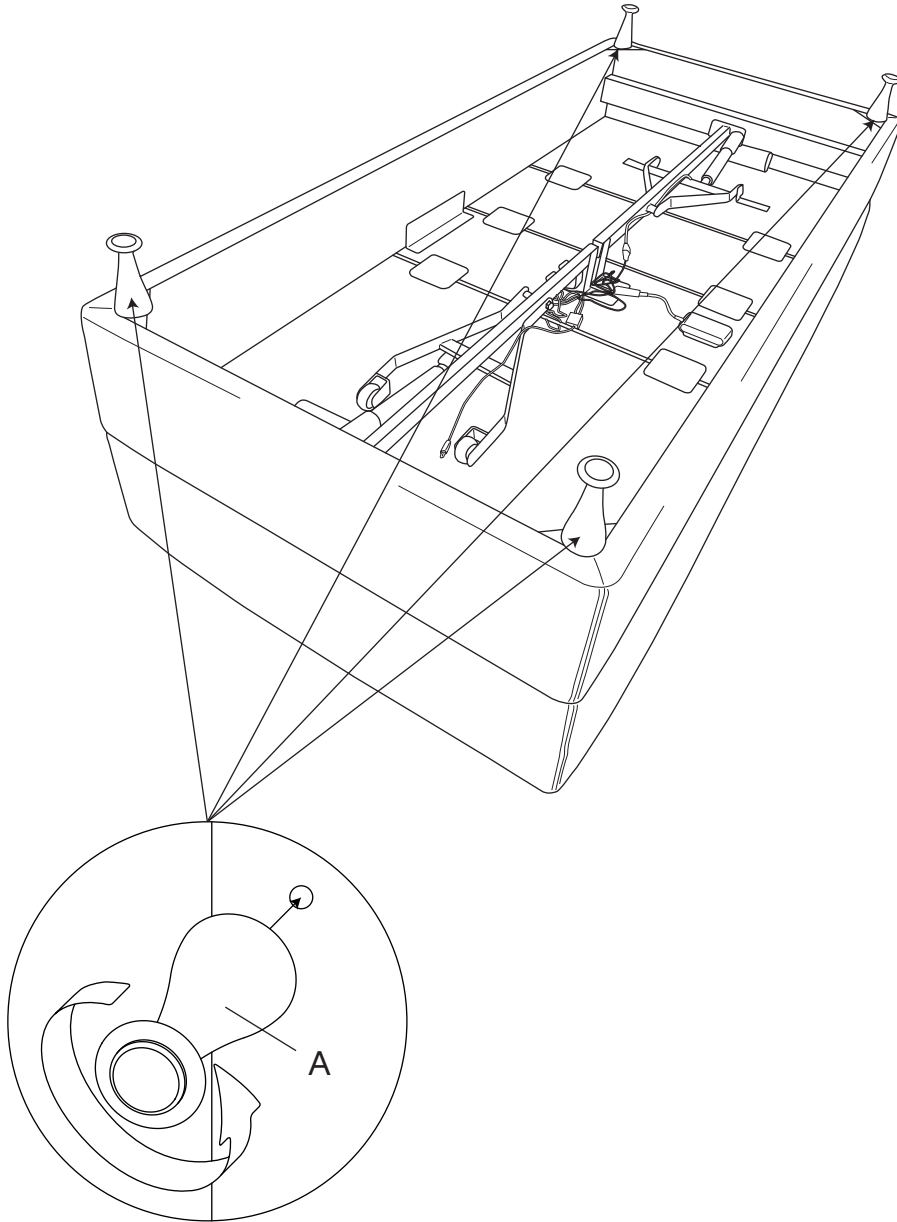

## **DISASSEMBLY / DEMONTERING**

Follow the instruction step by step.

Följ instruktionerna steg för steg.

6.

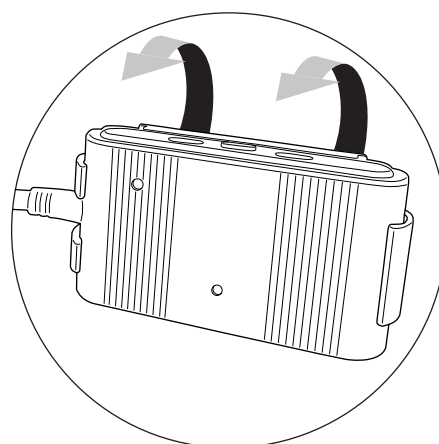
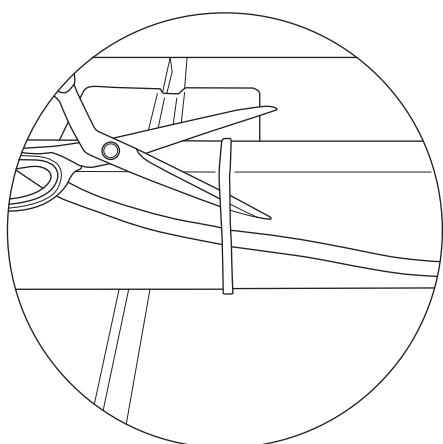
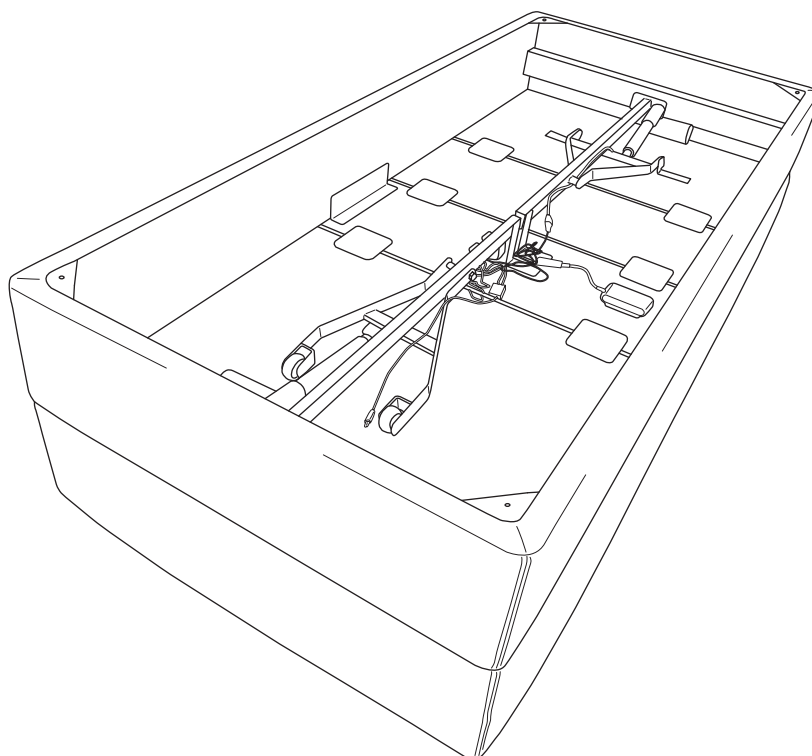

Carefully cut off the plastic straps that hold the wires in place. Detach the transmitter from the holder. Recycle cords, transmitters and remote controls as electrical waste.