

Aegis

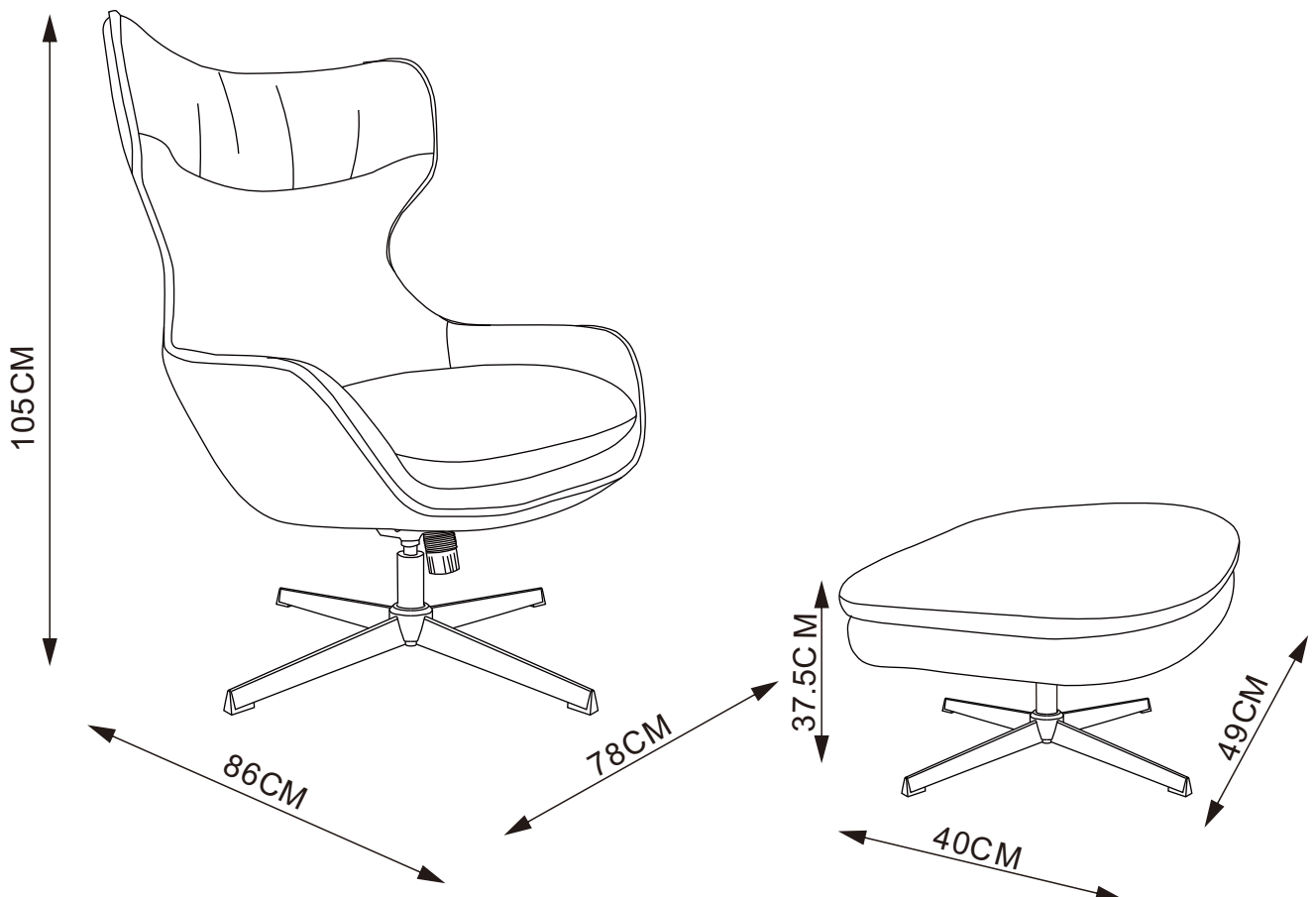

N: Viktig; Les nøye og oppbevar for bruk senere.

D: Wichtig! Sorgfältig lesen und für spätere Verwendung aufbewahren.

UK: Important! Read carefully and retain for future reference.

F: Important! A lire soigneusement et à conserver.

SE: Viktigt : Läs noggrant och spara för senare behov.

ES: Importante. Leer cuidadosamente las instrucciones y guardar para futuras referencias.

I: Importante! Leggere attentamente e conservare per future necessità.

N: For å unngå at møbelet får skader under montering anbefales det å montere møbelet på et mykt underlag, f.eks. på et teppe.

UK: Assembling of the furniture should take place on a soft surface e.g. a carpet in order to avoid scratching during assembly.

D: Um zu vermeiden, dass das Möbelstück gerissen wird, empfehlen wir unbedingt, es auf einer weichen Unterlage zu montieren - z.B. ein Teppich.

F: Afin d'éviter les rayures lors du montage, l'assemblage du meuble doit être effectué sur une surface douce - par exemple une couverture.

SE: För att möbeln inte ska repas vid montering bör den monteras på ett mjukt underlag - tex. på en matta.

ES: El montaje del sofa tiene que ser hecho en una superficie suave, como por ejemplo una alfombra o una manta, para evitar rozaduras durante el montaje.

I: Il montaggio dei mobili dovrebbe essere eseguito su una superficie morbida, ad esempio su un tappeto, per evitare rigature dovute all'assemblaggio.

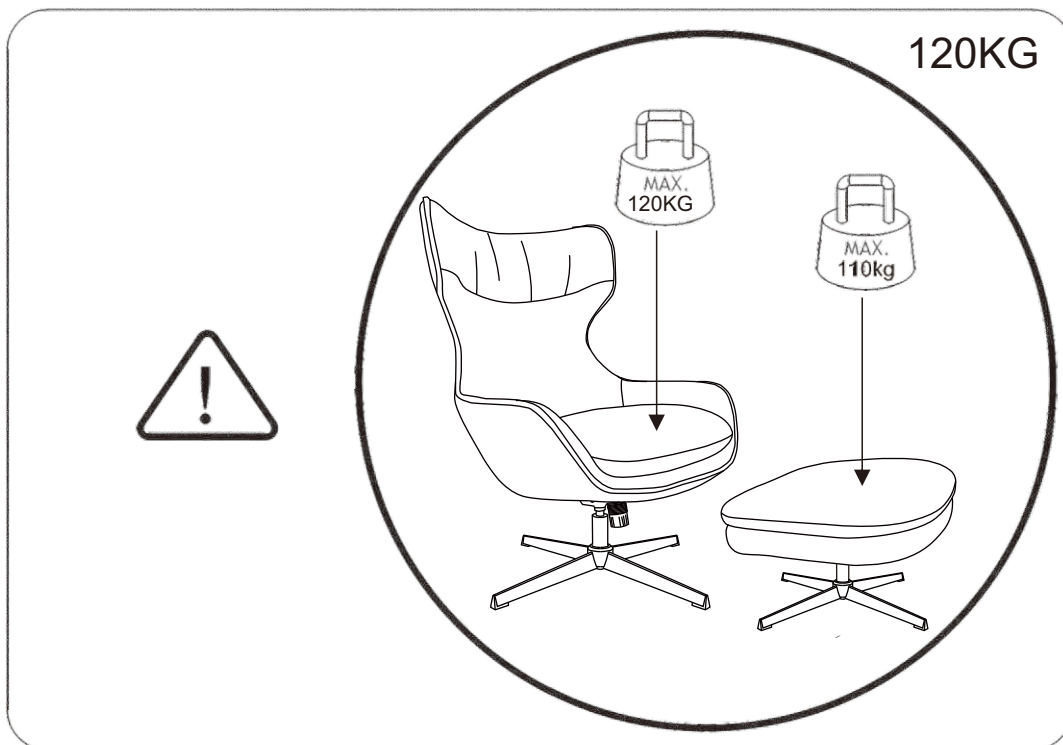
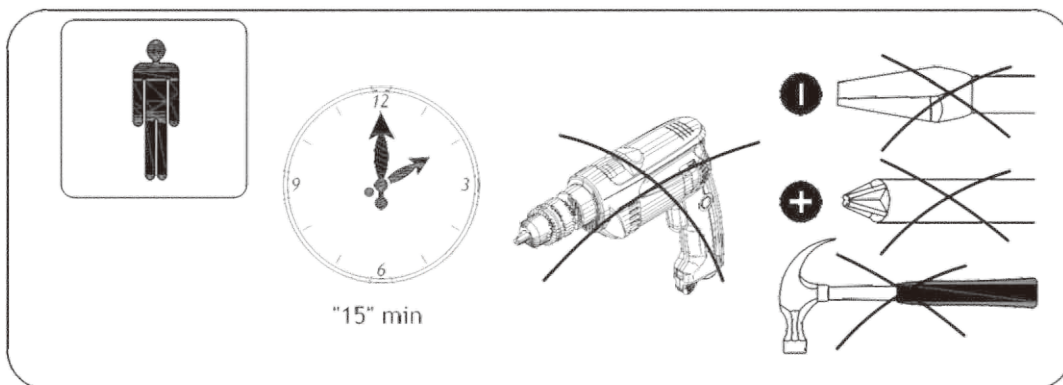
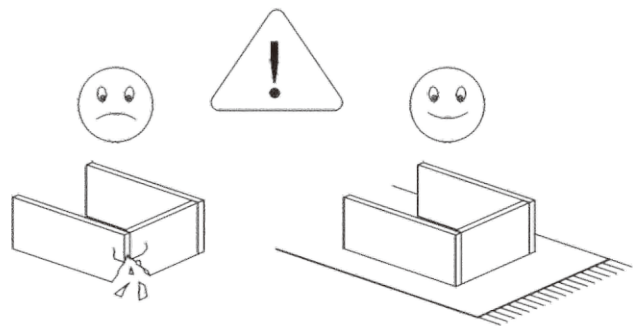



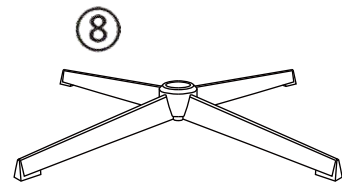
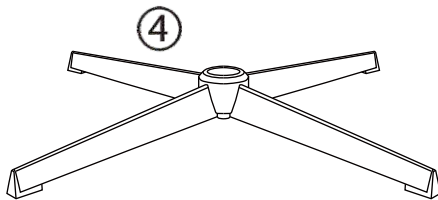
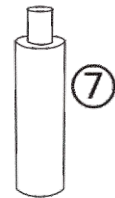
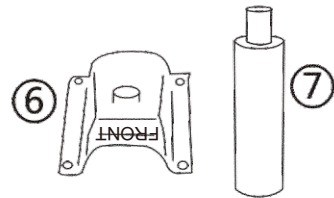
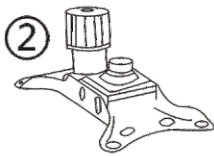
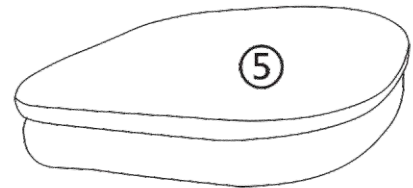
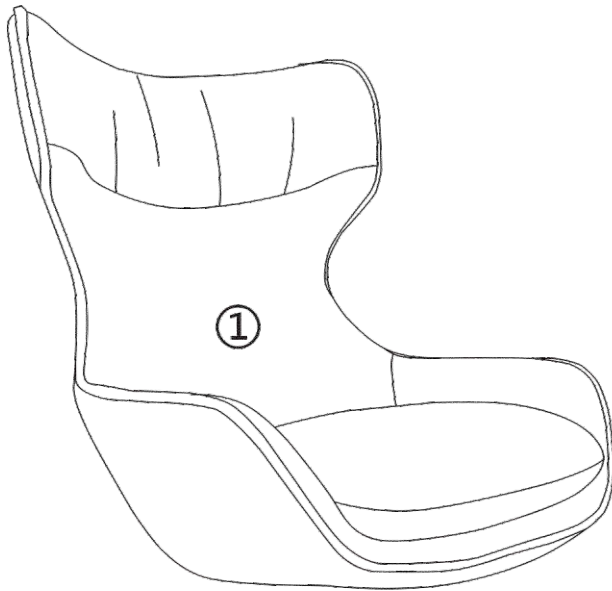

			CTN no.
①	1	780x810x880	1/1
②	1	280x170	1/1
③	1	150	1/1
④	1	540x540x80	1/1
⑤	1	490x400x115	1/1
⑥	1	230x160	1/1
⑦	1	220	1/1
⑧	1	350x350x80	1/1



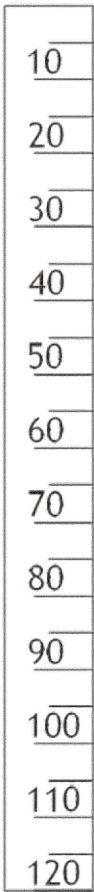

mm



A x 4	B x 2	C x 2	D x 1
			
M6*20mm	M6*25mm	M6*45mm	M6

N: Dersom det skulle være nødvendig å bestille reservedeler, vennligst oppgi både modell- og delenummer.

D: Falls Sie Ersatzteile benötigen, geben Sie bitte Modellnummer und Teilnummer, die Sie in der Montageanleitung findet an.

UK: In case you need spare parts please indicate model number and part number shown in the assembly instruction.



F: Dans le cas où vous auriez besoin de pièces détachées, nous vous prions de bien vouloir indiquer la référence du produit et celle de la pièce en question.

SE: Om det blir nödvändigt att beställa reservdelar, var vänlig uppge både modellnummer och det angivna numret på reservdelen.

ES: En caso de que usted necesite alguna pieza de cambio, por favor, indicar modelo y número conforme aparece en las instrucciones.



I: Nel caso in cui siano necessarie delle parti di ricambio, indicare il numero del modello e il numero della parte indicati nelle istruzioni di montaggio.

1

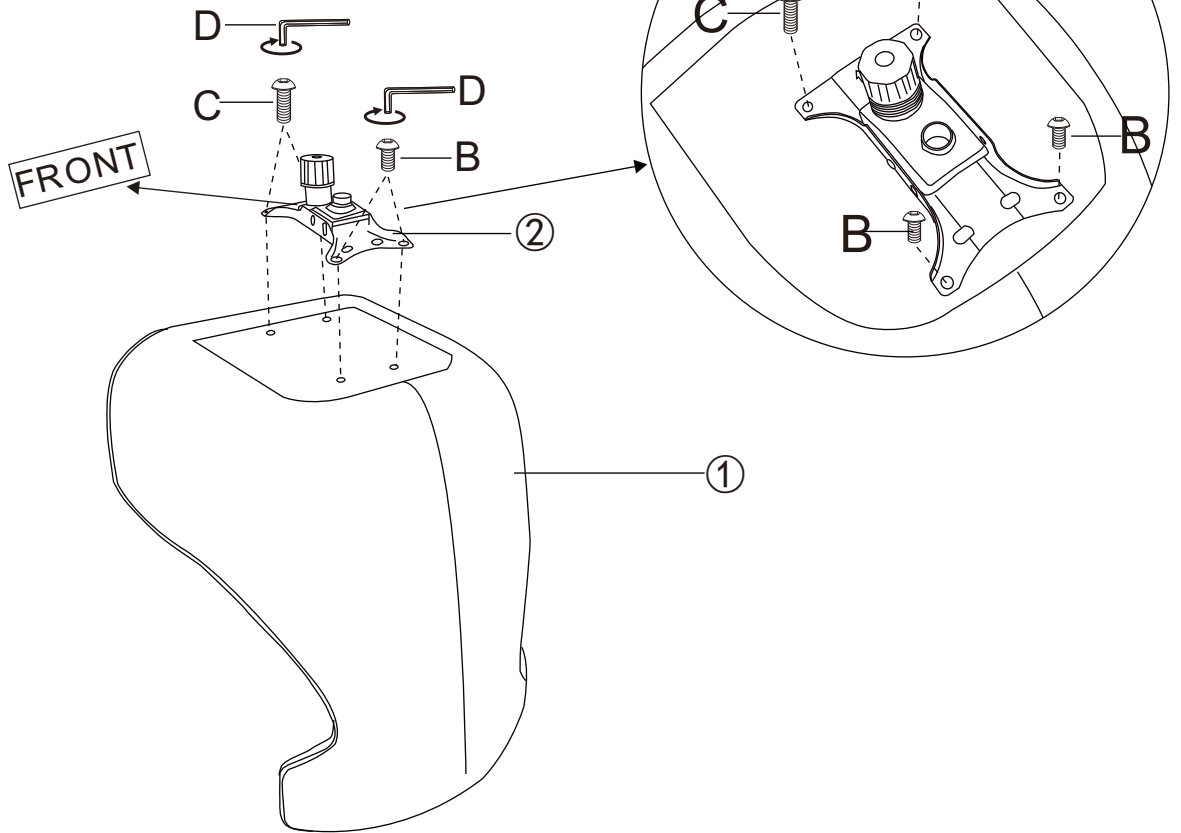
B x 2	C x 2	D x 1
		
M6*25mm	M6*45mm	M6



2

A x 4	D x 1
	
M6*20mm	M6

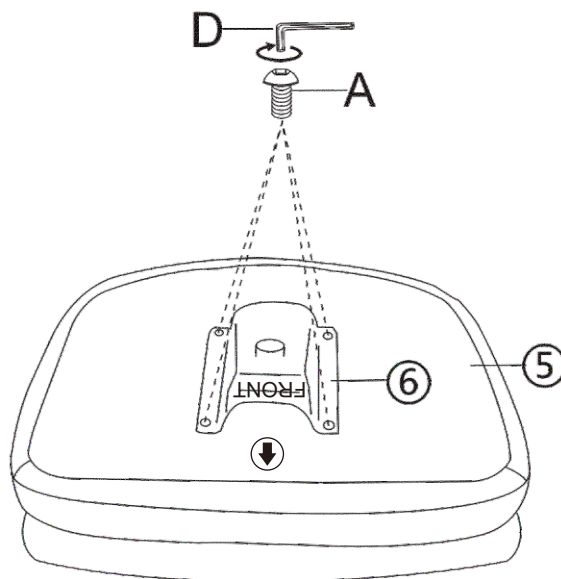

5-8

5002815

3

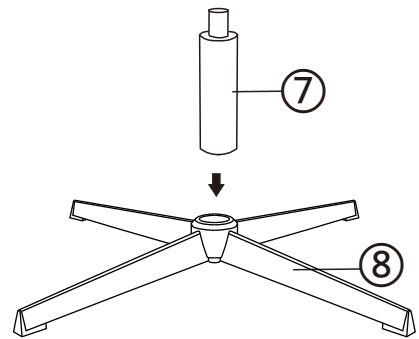
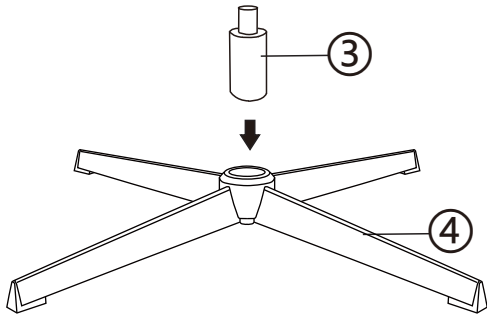

4



6-8

5



For å få glede av stolene i mange år fremover anbefales det å etterfeste skruene etter cirka 3 måneders bruk, og deretter etterskrues årlig.

In order to enjoy the chairs for many years to come, it is recommended to re-attach the screws after approximately 3 months of use, and then tighten the screws annually.

UK Please note!

As protection to your floor, this product has either pre-fixed foot caps or separately added foot caps. In addition we strongly recommend that you purchase felt pads and mount these onto the product prior to usage in order to protect your floor against pressure marks and scratches. Please note that you are responsible for regularly checking the foot caps and felt pads for correct mounting and replacing them regularly. In case of damage to your floor, the supplier of the product cannot be held responsible. Please contact your furniture store for further information

NO OBS!

For å beskytte gulvet mot trykkmerker og skraper er det levert eller formontert en standard benpropp. For å beskytte gulvet ytterligere anbefales det å sette på filtknott som fås kjøpt i de fleste møbelforretninger. Vi gjør oppmerksom på at De selv er ansvarlig for å sjekke at propper og filtknotter sitter riktig på og byttes regelmessig for å unngå skader på gulvet. Skader på gulv som følge av manglende bruk av filtknotter eller benpropp kan ikke belastes møbelprodusenten. Kontakt din møbelforhandler for ytterligere opplysninger.